



Fiber Optic Sensing Product Manual

Opti-Mag Sensor System™

U.S. Patent # 7,109,873 B2

and

FIBER FENCE

U.S. Patent # 6,980,108 B1

APPLICATIONS



FIBER OPTIC OVERVIEW

Congratulations on your purchase of the Fiber Fence / Opti-Mag Sensor System. We at Fiber Instrument Sales, Inc. are pleased to provide you with the latest in cutting-edge fiber optic security technology. This manual will introduce you to the basic concepts of fiber optics, as well as to the individual components that make up the Fiber Fence and Opti-Mag Sensor Systems.

Both the Fiber Fence Security System and the Opti-Mag Sensor System are essentially instruments composed of a light source, a receiver (known as a detector), and the various circuits and switches needed to control them.

The Opti-Mag Systems utilize light detection or reflection to set alarm. The light detection system injects light into one end of the sensing fiber and measures the amount of light that reaches the detector at the other end of the fiber. If the amount of light that reaches the detector drops below a preset threshold, an alarm signal is generated that is sent out through the dry contact relays on the back of the control unit. The reflection system (Mapping) reveals actual fault locations.

Caution: The light that these systems send out over the fiber is infrared (with a wavelength of 850-1550 nanometers, to be exact), is invisible to the human eye, and can damage the eye. For this reason, do not look into any activated ports.

What is "Fiber Optics?"

The term "Fiber Optics" refers to a type of technology used in many different industries, including Industrial and Home Lighting, Telecommunications, Cable Television, High-speed Internet, and many others.

While the specific details vary for each industry, the basic concept is the same: an optical fiber (made of either plastic or glass) is used to guide light from one point to another. For purposes of this discussion, we will be dealing with glass fiber which is widely used in telecommunications and cable television (CATV).

The overall diameter of the entire glass fiber is roughly the diameter of a human hair. The light signal that it carries travels only in the very center, known as the core, which is only 1/10th the diameter of the overall fiber. A powerful microscope is needed to see the actual core! The black jacket that you see covering the fiber contained in your system is used to protect the glass during handling, from the weather, and from the sun's UV rays.

In order to create a fiber optic communications link, three basic components are needed: a light source (used to inject light into the fiber), the fiber itself, and a receiver (to detect the light at the other end of the fiber). Once light is injected into the fiber by the source, it is "trapped" in the core, and allows the fiber to be installed around corners and large bends. **When properly installed**, fiber optic technology is largely unaffected by turns and bends in the fiber fence line configuration, or other security zones being monitored.

When handling fiber optic cable, there are a few basic guidelines to remember. First of all, always keep in mind that the glass fiber is fragile, and handle it accordingly (common

sense will keep you out of trouble-if you think something will break the cable, it probably will). Some of the Do's and Don'ts of fiber handling are below:

While the core of a fiber is designed to be highly efficient when guiding the light from one end to the other, there are circumstances that will reduce the amount of light that makes it all the way through the fiber, or possibly stop the light transmission altogether.

First, fiber optic cables (including that cable used in the Fiber Fence and Opti-Mag Systems) carry a specification known as minimum bend radius. The minimum bend radius is the smallest bend that can be applied to the cable at any given point without causing a loss of light. The minimum bend radius for the sensing fiber used here is four (4 cm) centimeters or 1.5 inches. Therefore in order to avoid a loss of light, any loop formed with the sensing fiber must be larger than eight centimeters (8 cm) or 1.5" in diameter.

Because the amount of light loss increases exponentially as the bend radius decreases, careful attention to this requirement is an absolute must when installing the fiber to ensure that the minimum bend radius is never violated.

Secondly, if the radius becomes too small (if, for instance, the loop is pulled tight) the actual glass fiber could break inside the jacket. Light will not pass beyond the break point even if the jacket remains intact (the cable could still be continuous, with the fiber broken inside of it).

Common sense will keep you out of trouble; glass fiber is fragile, and always handle it accordingly. Keeping the following basic fiber optic cable handling guidelines in mind will help you to avoid damaging the sensing cable during handling and installation:

DON'T

- Pull hard on the cable, especially when un-spooling the fiber along the fence.
- Pull the cable tight around a corner or other sharp bend.
- Cut the cable, for any reason (once it has been cut, special equipment and skills are needed to put it back together).
- Rush. Always take your time and be patient; this will help ensure that the cable is installed right the first time, and will help prevent frustration in the future.

DO

- Be gentle with the cable at all times.
- Exercise care to ensure that the cable does not twist or tangle; if it does, slowly and carefully untangle and untwist the cable.
- Take your time...

TABLE OF CONTENTS

PART I : Opti-Mag Sensor System™

Opti-Mag Sensor System General Overview	1
Typical System Configurations	2
Components Utilized	3
Opti-Mag Mapping	5
Mounting the Sensor	6
Connecting to the Zoning Control Unit	7

PART II : Fiber Fence Security System

Fiber Fence Security System General Overview	8
Components Utilized	9
Fiber Fence Mapping	11
Fiber Fence Installation Techniques	12
Connecting to the Zoning Control Unit	18

PART III : Detailed Fiber Fence Installation Instructions

Fiber Fence Installation	19
--------------------------------	----

PART IV : Component Specifications

PART V : Application Guide and Quote Form

“Fiber Optic technology is the optimal solution for long-distance applications or for use in non-spark environments.”

1. OPTI-MAG SENSOR SYSTEM

General Overview

The Opti-Mag Sensor System is used in those applications where the position, proximity, presence (or absence) of doors, covers, levers, and similar components must be monitored. Common examples include mineshaft doors, manhole covers, gates, and pipeline valve handles.

Because Opti-Mag Sensors require no electrical power and instead utilize an internal, magnetic plunger mechanism to attenuate the fiber when the sensed object is removed or otherwise moved outside of the specified sensing zone, they can be used in remote areas and/or flammable environments where sparks cannot be allowed.

Opti-Mag Sensors have no external moving components, and do NOT require being in direct contact with the contact surface being sensed. They are also ideal for use in wet or corrosive environments, unlike traditional sensors that commonly “stick” and fail due to internal corrosion.

Opti-Mag Sensors require splicing of the fiber and connectorization at the sensing location. It is highly recommended that the “fiber splicing portion” of the installation be performed by a fiber optic technician. Fusion or Mechanical splicing is acceptable.

Pre-connectorized cable and sensors are available. Please contact Fiber Instrument Sales for more information. FIS University offers training in basic and advanced fiber optics.

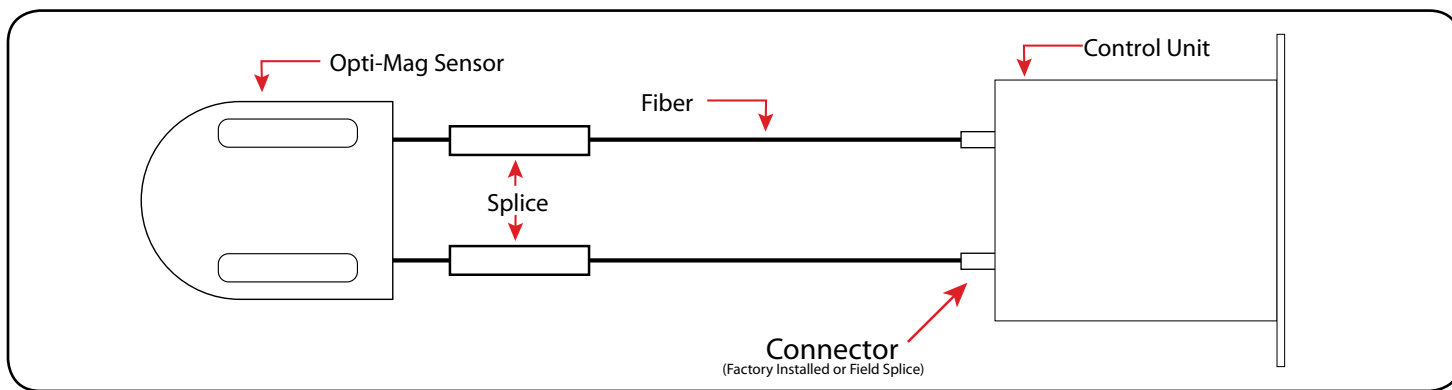
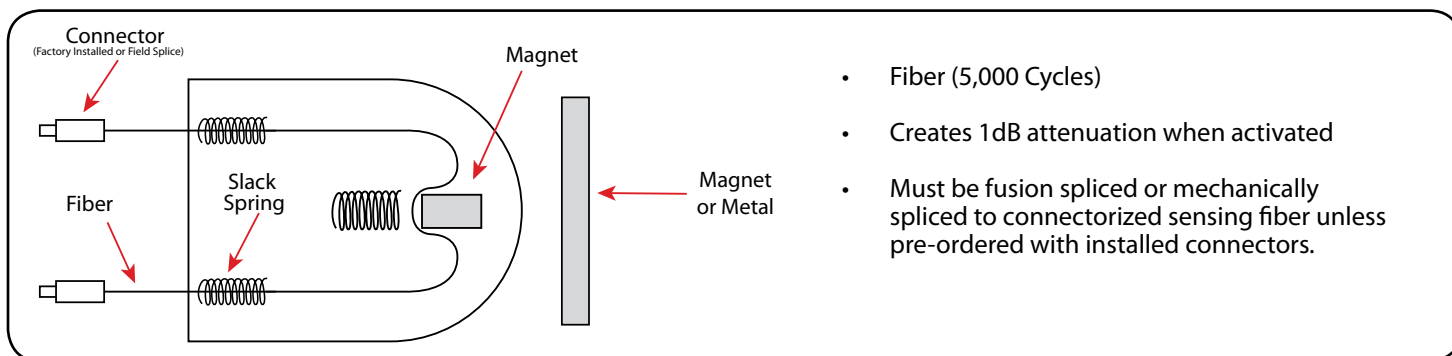

Distance Advantage for Non-Spark Environments

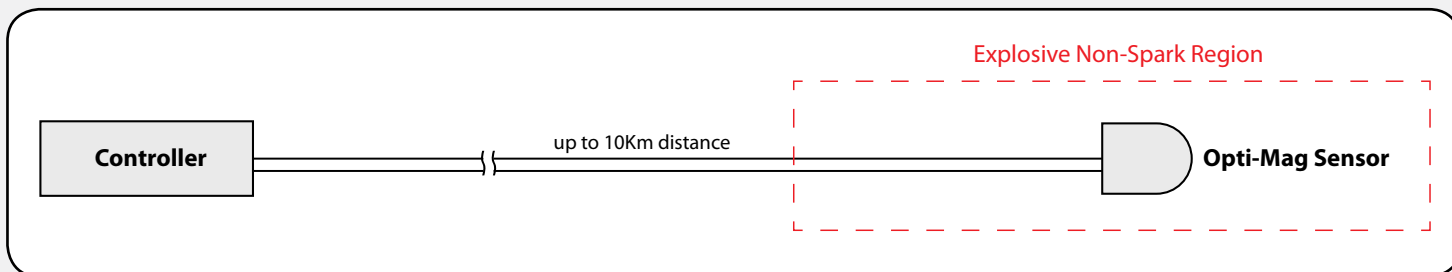

Typical System Configurations

“Home Runs”

Using duplex fiber cable each sensor sets off alarm identifying sensor location.

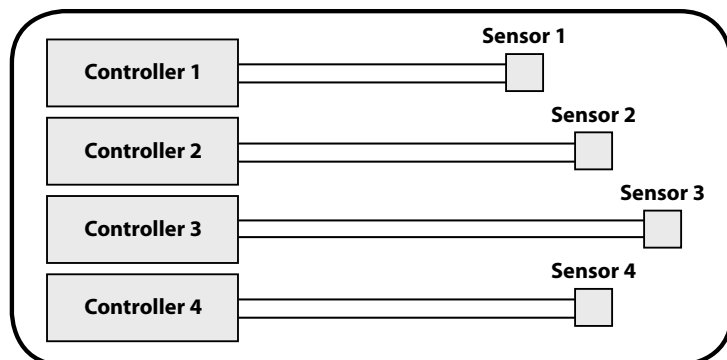

Shows four “Home Run” Sensor Modules

“Series”

Using simplex fiber cable, sensors may be placed in a series.

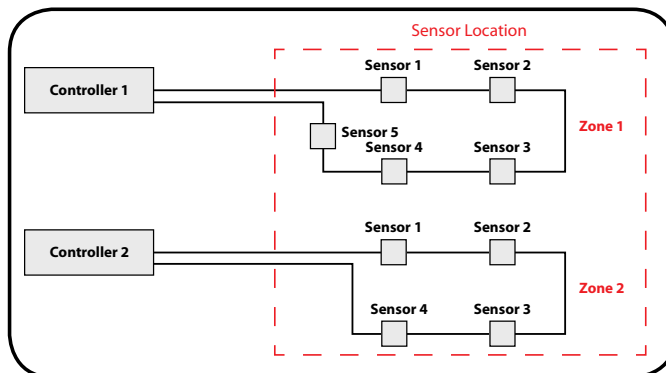

Shows two “Series” over two zones

When connecting ten or more sensors in series, a 23dB dynamic range or the laser controller unit (part number **OMS-CML**) must be used.

NOTE: Each controller may be identified as a zone.

(If “Connectorizing” fiber to sensors (2 each) at 1 dB loss per connector, ten sensors in series create 20dB loss, allowing a 3dB fiber loss. Using a “fusion splicer” for all splicing would enable serializing up to 20 sensors.

IMPORTANT: When installing fiber cable around corners, secure it loosely to avoid tight bends that will create additional attenuation.

“...unprotected manholes offer terrorists a relatively easy way to inflict damage which ranges from the merely disruptive to the seriously debilitating.”

(from: Manhole Security and U.S. Critical Infrastructure, Homeland Security Newswire)

2. COMPONENTS UTILIZED

Opti-Mag Sensor (PN: OMS-PRX)



Opti-Mag Sensors use fiber optic based technology that allows sensing in locations that can extend for miles. They require no electrical power at the sensor location, making them extremely useful in remote areas where there is often no electrical service. They can also be used in flammable environments where electrical arcing (sparking) is prohibited. Being that there are no external moving parts, Opti-Mag Sensors have a long, reliable sensing life. The Opti-Mag Sensor does not require being in direct contact with the surface it is sensing.

SPECIFICATIONS

Fiber Type	9/125, 900µm UV Resistant Jacket
Operating Temperature	-30°C to +63°C (-22°F to +145°F)
Minium Ferrous Metal Target	2" x 2" x 1/8" thick
Dimensions	3.250"H x 2.375"W x 1.125"D
Weight	6.0 ounces
Maximum Target Distance	0.04 inches
Durability	5000 intermittent cycles
Housing Material	Glass Filled ABS
Attenuation	1dB

Zoning Control Unit OMS-CMV (standard) OMS-CML (extended)



The Zoning Control Unit is the heart of both the Opti-Mag Sensor and the Fiber Fence Sensor Systems. Using a laser, the Control Unit sends light through the fiber optic cable to one or more Opti-Mag or Mouse Trip sensors to which it is connected. When one of those sensors detect an event, the amount of light sent back to the Control Unit is reduced, thus causing the Unit to trigger a relay switch that can provide any number of desired outcomes. Multiple control units provide multiple zone location sensing. For example, the relay can be configured to sound an alarm to an automated telephone dialup system.

The Zoning Control Unit is available in two different light source models; an 850NM VCSEL unit for standard (3km) transmission range applications, or a 1310NM high-power laser for use in extended range applications (10km.) Use the appropriate Zoning Control Unit based on the total perimeter length of the installation application.



On/Off Switch: self explanatory

LED Indicators:

“Calibrated” illuminates when the power is switched on and unit completes Auto Cal.

“Alarm” illuminates when the Zoning Module has detected an intrusion.

Mute Switch: turns the built-in audible alarm on or off.

Latch/Non-Latch Switch

When in “Latch” mode, the “Alarm Reset” button must be pushed after an alarm has been detected in order to begin monitoring the fiber again.

When in “Non-Latch” mode, the Zoning Control Unit automatically resets itself when the alarm condition is removed.

Rear Panel:

Power Input Jack: Connect the 9VDC transformer.

NO/NC Dry Contacts: Two relay outputs, one normally open and one normally closed, are provided to allow the user to connect the Zoning Module to an existing alarm system or to other security accessories.

Fiber Optic Connection Ports: This is where the sensing cable attaches to the Zoning Module .

Part #	OMS-CML	OMS-CMV
Trans. Range	10Km	3 Km
Dyn. Range	23dB	8dB
Op. Wavelength	1310nm SM	850nm SM
Power Requirements	110 Vac 50-60 Hz	
Operational Voltage	9 Vdc 300mA (center positive)	

* A 220 Vac - 9Vdc 2A is available upon request

Refer to Product Specification Sheets for Additional Information.

Fiber Cable

Opti-Mag and Fiber Fence sensor systems utilize either simplex or duplex 9/125 bend sensitive fiber cable with a UV protected jacket. Part number for the simplex fiber is **OMS-SMPX** and the part number for duplex fiber is **OMS-DPX**. **CONSULT FACTORY FOR YOUR APPLICATION.**

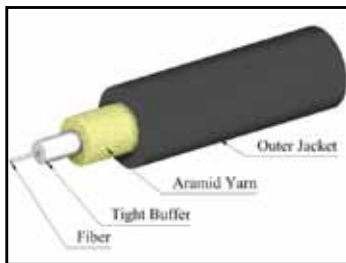

Simplex Cable

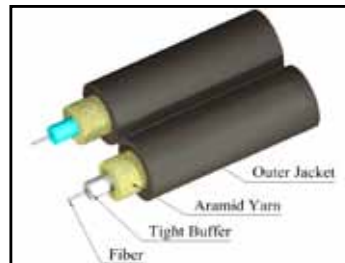

Duplex Cable

Splice Protection Kit (PN: OMS-SPK)

Splice Protection Kits are used to protect and to insure the integrity of the fiber cable fusion (or mechanical) splices created for system installation. (Refer to page 14 for procedural instructions)

Kit Contains:

- a. 1 - 4" metal protection tube
- b. 1 - 5" black shrink tube
- c. 2 - 1" clear shrink tube
- d. 1 - copper mounting bracket
- e. 1 - splice sleeve for fusion splice

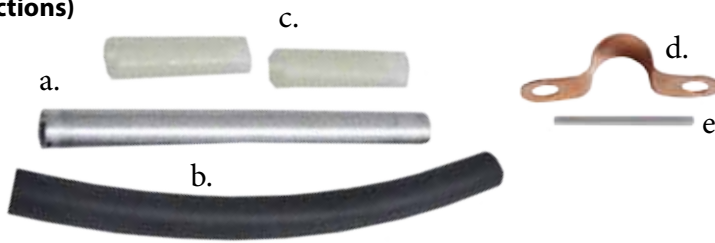

Optional Splice Enclosures (PN: OMS-ENCL)

The Splice Enclosure provides additional protection for interior/exterior fusion (or mechanical) splice locations, or at system perimeter gate locations. It is recommended that Splice Protection Kit (PN: OMS-SPK) be used in conjunction with this enclosure. (Refer to page 14 mounting instructions)



Optional Rack and Power Supply

Each Fiber Instrument Sales' 2RU rack (PN: OMS-RMS) safely and conveniently holds up to four Zoning Control Units. Control Units can be installed in the rack upon request. If three or less units are required, use blank (PN: OMS-BLNK) to cover the open slot.

Note: the single power supply included in the purchase of each Zoning Control Unit is capable of powering up to four (4) Control Units. Additional power supplies are available using PN: OMS-PWRS. (220 Vac - 9Vdc 2A power supplies are available upon request. PN: OMS-PWRS220.)



Zip Ties (PN: OMS-DHZT)

Use double headed UV resistant zip ties to secure the sensing fiber to the fence.
(Refer to page 16 for mounting instructions)



Optional Mapping System (PN: OMS-MAP)

The optional 18dB range Mapping System utilizes Fiber Instrument Sales' unique software and an embedded **OTDR technology allows for the monitoring of an unlimited number of security zones and the ability to identify the exact locations of triggered Mouse Trip or Opti-Mag Sensors.** The System's 4.5" integrated monitor graphically displays the triggered sensor locations on a photo or diagram of the facility. The Optional Mapping System replaces the standard Zoning Control Unit.



The Mapping System's typical range is approximately 10km. Longer range systems are available.

Any tripped Mouse Trip location will be shown on the monitor.

Identifying The Tripped Sensor Location Using the Mapping System

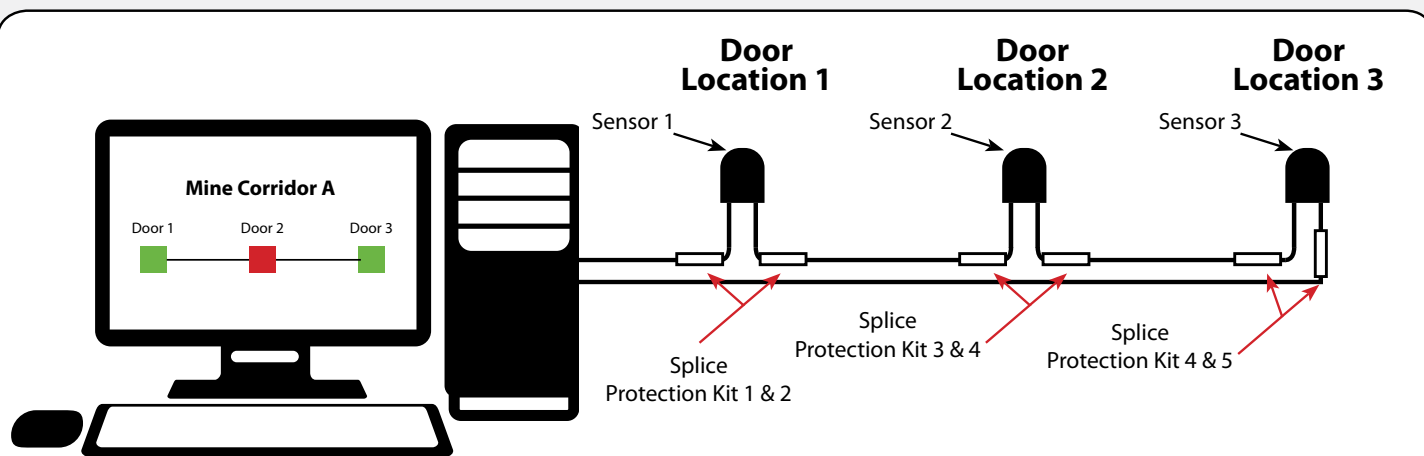

Unlike the "Zoning Control Unit," which gives acknowledgement that there is an intrusion or breach, the "Mapping System" will display on the monitor the actual location of the "tripped" sensor. Any tripped sensor location will be shown on the monitor.

In this diagram a pictorial of a mine corridor application with door locations 1, 2 and 3 in a series are shown. The tripped location at door #2 appears in red, indicating a possible intrusion or breach. "Door 2" has been activated.

NOTE: As many as 20 sensors may be connected in a series when fusion splicing.

3. MOUNTING THE SENSOR

The target component material (e.g. lever, switch, hatch cover, etc.) to be monitored must be capable of being detected by the magnet contained within the Opti-Mag sensor. If the target material is not magnetic, a bracket or plate (made of a magnetic material) can be affixed to the target. The Opti-Mag Sensor's normal sensing distance to the target should not exceed .040" the standard (magnetic) metal bracket is **part number OMS-BRK**.

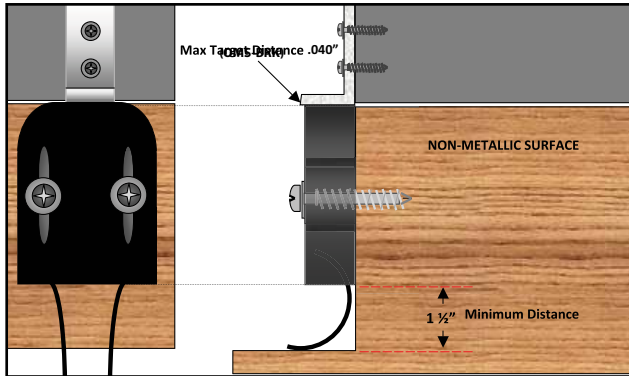

Opti-Mag Single Magnet Setup

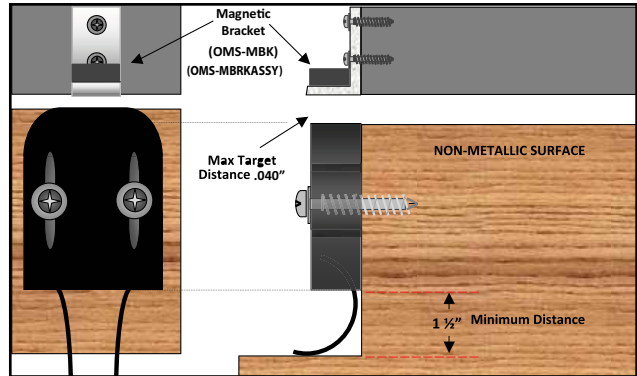

Opti-Mag Double Magnet Setup

For applications in which the distance from the Sensor to the target exceeds 0.040," Fiber Instrument Sales recommends the use of a supplemental magnet / bracket assembly (PN: OMS-MBRKASSY) that is easily affixed to the target surface.

Example 1

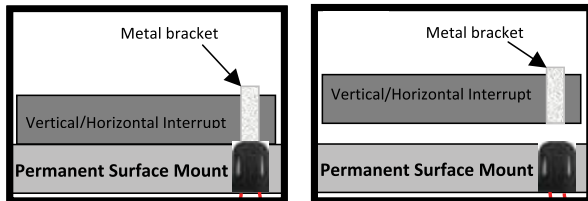

Normal Position

Activated Position

Example 2

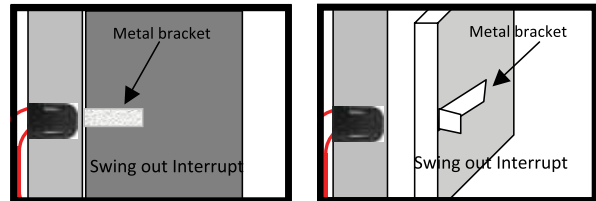

Normal Position

Activated Position

Example 3

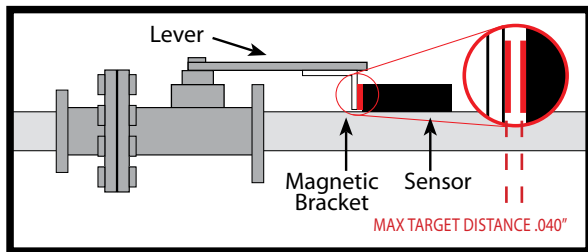

Normal Position (Side View)

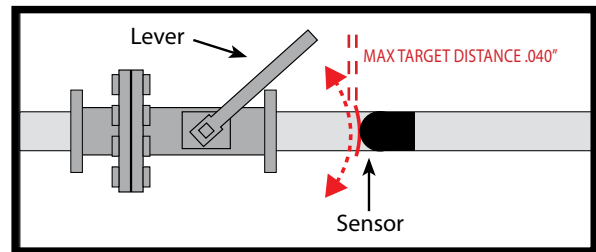

Activated Position (Top View)

Example 4

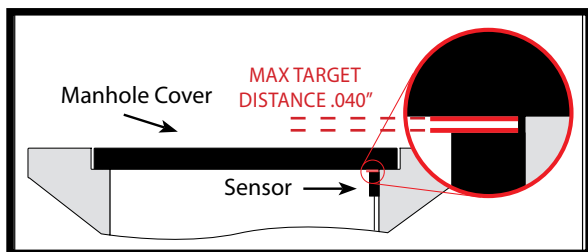

Normal Position

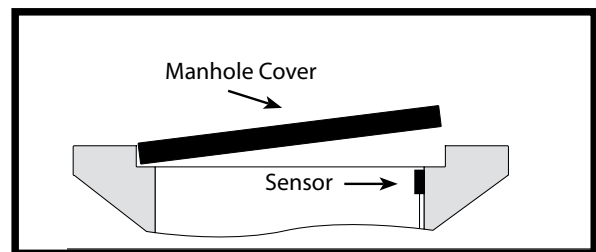

Activated Position

4. CONNECTING TO THE ZONING CONTROL UNIT

STEP 1. Before turning the unit on, connect both ends of the fiber sensing loop into the fiber loop receptacles on the back panel of the unit.

- a. This device contains a class I laser. Do not look directly into the fiber loop receptacles while the device is powered.
- b. The fiber receptacles on the back of the unit are for FC or SC connectors. Be sure the key on the FC connector is lined up with the slot in the receptacle before tightening the connector.

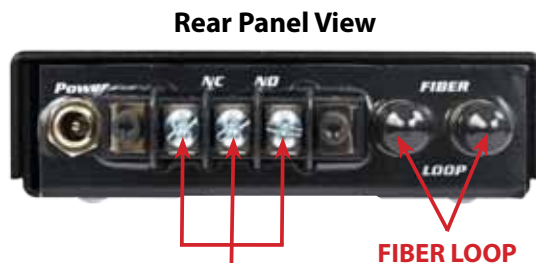

Terminal Block – A 3-pin terminal block is located in the back panel to provide a normally open (NO) and normally closed (NC) contact to trigger an external alarming device (siren, flashing light, etc.). This connection is a switch capable of carrying 3 amps (3A) of current.

STEP 2. Connect the 9V power supply that is included with the unit to the power connector on the back of the unit.



STEP 3. Apply power to the unit by toggling the power switch to the "I" position.

- a. The green "calibrated" LED will light to indicate that self-calibration of the unit is in progress.
- b. The green "calibrated" LED will blink once to indicate the self-calibration completed successfully.



STEP 4. It is recommended the alarm be tested by deliberately triggering the unit into alarm condition with a fiber event (fiber attenuation, fiber disconnect, or cover cop activation).

- a. The red "alarm" LED should light in alarm.
- b. The audible alarm should sound, if the "Mute" button is off.
- c. If the unit is in "Latch" mode, the red "alarm" LED and audible alarm will be present even after the alarm event has been corrected. Press the reset button to clear the alarm if in "Latch" mode.

Front Panel View



Front Panel Features:

- **Mute** – enables and disables the audible alarm.
- **Latch** – allows the unit to remain in alarm, even after the alarm event has been corrected, until the reset button has been pressed.
- **Reset** – Press to clear alarm in latch mode after the alarm event has been corrected.

1. FIBER FENCE SECURITY SYSTEM

General Overview

The Fiber Fence Security System is used primarily for detecting intrusion into large perimeters, such as those areas around factories, water reservoirs, airports and similar secure locations. The Fiber Fence System can also be used to secure small areas containing machinery, hazardous waste containers, or similar containment areas where disturbing the fiber surrounding the secured location or device triggers the sensor to send a signal to the Zoning Control Unit.

When used in conjunction with the optional Fiber Fence Mapping System, the exact location of the disturbance can be reported.

Specific applications in which Fiber Fence systems have also been used include secure military facilities, nuclear power plants, storage yards, hazardous waste facilities, power utility substations and more.

In perimeter fence line applications, the System operates utilizing "Mouse Trip" devices mounted at regular intervals along the fence line. Fiber optic cable threaded through the "Mouse Trip" mechanism is attenuated when the fence is disturbed. This attenuation in the fiber is detected by the Zoning Control Unit, resulting in a system alert condition.

System range depends on the application, perimeter distance and type of Zoning Control Unit being used. Perimeter distances from 2k to 10k are typically achieved. Higher power Zoning Control Units for extended distances are available.

IMPORTANT NOTICE

Fiber Fence Systems **MUST** be installed by fiber optic technicians. Consult a local fiber optic contractor or confirm installation team possesses the ability to: **splice fiber, connectorize fiber, hang fiber, test fiber and OTDR operation.**

The images to the right depict Fiber Fence Security installations. Installations use different configuration styles to meet the needs of particular customers.



CHEMICAL PLANTS



MANHOLE COVERS



OIL RIG PLATFORMS



MINING OPERATIONS



NO SPARK ENVIRONMENTS



PIPELINES, RAILS, BRIDGES

Utilize Either a Zoning Control Unit or Mapping System for Perimeter Application

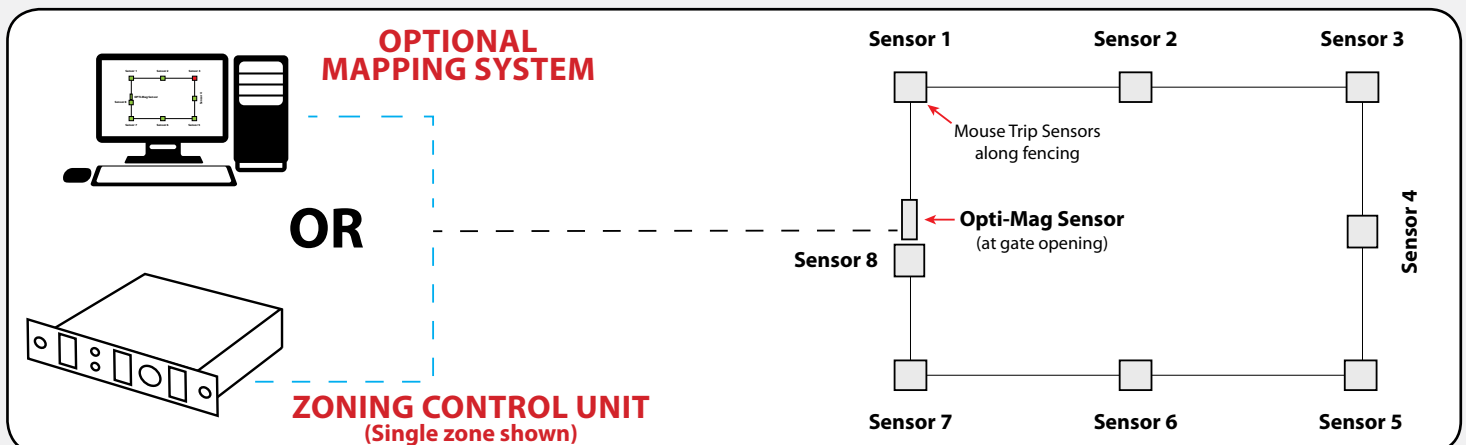

2. COMPONENTS UTILIZED

Mouse Trip Sensor (PN: OMS-MT)



Mouse Trip Sensors are designed to be mounted to the fence line and operate with 9/125µm sensing fiber. When tripped, an internal plunger creates a loss of light which is recognized by the Zoning Control Unit and activates an alarm. Mouse Trip Sensors are water resistant, dust proof, UV protected, and are designed to withstand extreme temperature fluctuations for dependable performance during extended deployment in harsh weather environments.

All Mouse Trip Sensors come equipped with a reset feature that allows for quick resetting using a special tool (included) without having to open the Unit.

The Mouse Trip Sensor requires minimal maintenance throughout its service life, and once installed will provide many years of reliable protection.

SPECIFICATIONS

Materials	UV Protected ABS
Operating Temperature	-20°C to 60°C (-68°F to +140°F)
Power Requirements	None
Dimensions	9.75" L X 3.1" W X 6.00" H
Fiber Type	9/125µm
Mounting Type	Pole, Wall (Concrete or Brick)

Zoning Control Unit OMS-CMV (standard) OMS-CML (extended)



The Zoning Control Unit is the heart of both the Opti-Mag Sensor and the Fiber Fence Sensor Systems. Using a laser, the Control Unit sends light through the fiber optic cable to one or more Opti-Mag or Mouse Trip sensors to which it is connected. When one of those sensors detect an event, the amount of light sent back to the Control Unit is reduced, thus causing the Unit to trigger a relay switch that can provide any number of desired outcomes. Multiple control units provide multiple zone location sensing. For example, the relay can be configured to sound an alarm to an automated telephone dialup system.

The Zoning Control Unit is available in two different light source models; an 850NM VCSEL unit for standard (3km) transmission range applications, or a 1310NM high-power laser for use in extended range applications (10km.) Use the appropriate Zoning Control Unit based on the total perimeter length of the installation application.



On/Off Switch: self explanatory

LED Indicators:

“Calibrated” illuminates when the power is switched on and unit completes Auto Cal.

“Alarm” illuminates when the Zoning Module has detected an intrusion.

Mute Switch: turns the built-in audible alarm on or off.

Latch/Non-Latch Switch

When in “Latch” mode, the “Alarm Reset” button must be pushed after an alarm has been detected in order to begin monitoring the fiber again.

When in “Non-Latch” mode, the Zoning Control Unit automatically resets itself when the alarm condition is removed.

Rear Panel:

Power Input Jack: Connect the 9VDC transformer.

NO/NC Dry Contacts: Two relay outputs, one normally open and one normally closed, are provided to allow the user to connect the Zoning Module to an existing alarm system or to other security accessories.

Fiber Optic Connection Ports: This is where the sensing cable attaches to the Zoning Module.

Part #	OMS-CML	OMS-CMV
Trans. Range	10Km	3 Km
Dyn. Range	23dB	8dB
Op. Wavelength	1310nm SM	850nm SM
Power Requirements	110 Vac 50-60 Hz	
Operational Voltage	9 Vdc 300mA (center positive)	

* A 220 Vac - 9Vdc 2A is available upon request
Refer to Product Specification Sheets for Additional Information.

Fiber Cable

Opti-Mag and Fiber Fence sensor systems utilize either simplex or duplex 9/125 bend sensitive fiber cable with a UV protected jacket. Part number for the simplex fiber is **OMS-SMPX**.

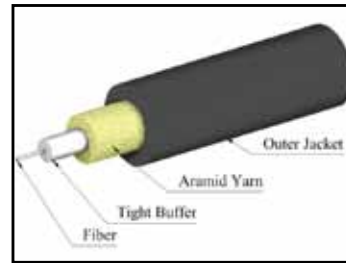

Simplex Cable

Splice Protection Kit (PN: OMS-SPK)

Splice Protection Kits are used to protect and to insure the integrity of the fiber cable fusion (or mechanical) splices created for system installation. **(Refer to page 14 for procedural instructions)**

Kit Contains:

- a. 1 - 4" metal protection tube
- b. 1 - 5" black shrink tube
- c. 2 - 1" clear shrink tube
- d. 1 - copper mounting bracket
- e. 1 - splice sleeve for fusion splice

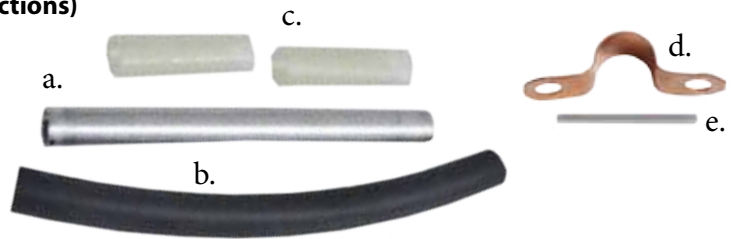

Optional Splice Enclosures (PN: OMS-ENCL)

The Splice Enclosure provides additional protection for interior/exterior fusion (or mechanical) splice locations, or at system perimeter gate locations. It is recommended that Splice Protection Kit **(PN: OMS-SPK)** be used in conjunction with this enclosure. **(Refer to page 14 mounting instructions)**



Optional Rack and Power Supply

Each Fiber Instrument Sales' 2RU rack **(PN: OMS-RMS)** safely and conveniently holds up to four Zoning Control Units. Control Units can be installed in the rack upon request. If three or less units are required, use blank **(PN: OMS-BLNK)** to cover the open slot.

Note: the single power supply included in the purchase of each Zoning Control Unit is capable of powering up to four (4) Control Units. Additional power supplies are available using **PN: OMS-PWRS**. (220 Vac - 9Vdc 2A power supplies are available upon request. **PN: OMS-PWRS220**.)



Zip Ties (PN: OMS-DHZT)

Use double headed UV resistant zip ties to secure the sensing fiber to the fence.
(Refer to page 16 for mounting instructions)



Optional Mapping System

(PN: OMS-MAP)

The optional 18dB range Mapping System utilizes Fiber Instrument Sales' unique software and an embedded **OTDR technology allows for the monitoring of an unlimited number of security zones and the ability to identify the exact locations of triggered Mouse Trip or Opti-Mag Sensors.** The System's 4.5" integrated monitor graphically displays the triggered sensor locations on a photo or diagram of the facility. The Optional Mapping System replaces the standard Zoning Control Unit.

The Mapping System's typical range is approximately 10km. Longer range systems are available.

Any tripped Mouse Trip location will be shown on the monitor.



Schematic Of Tripped Sensor Location

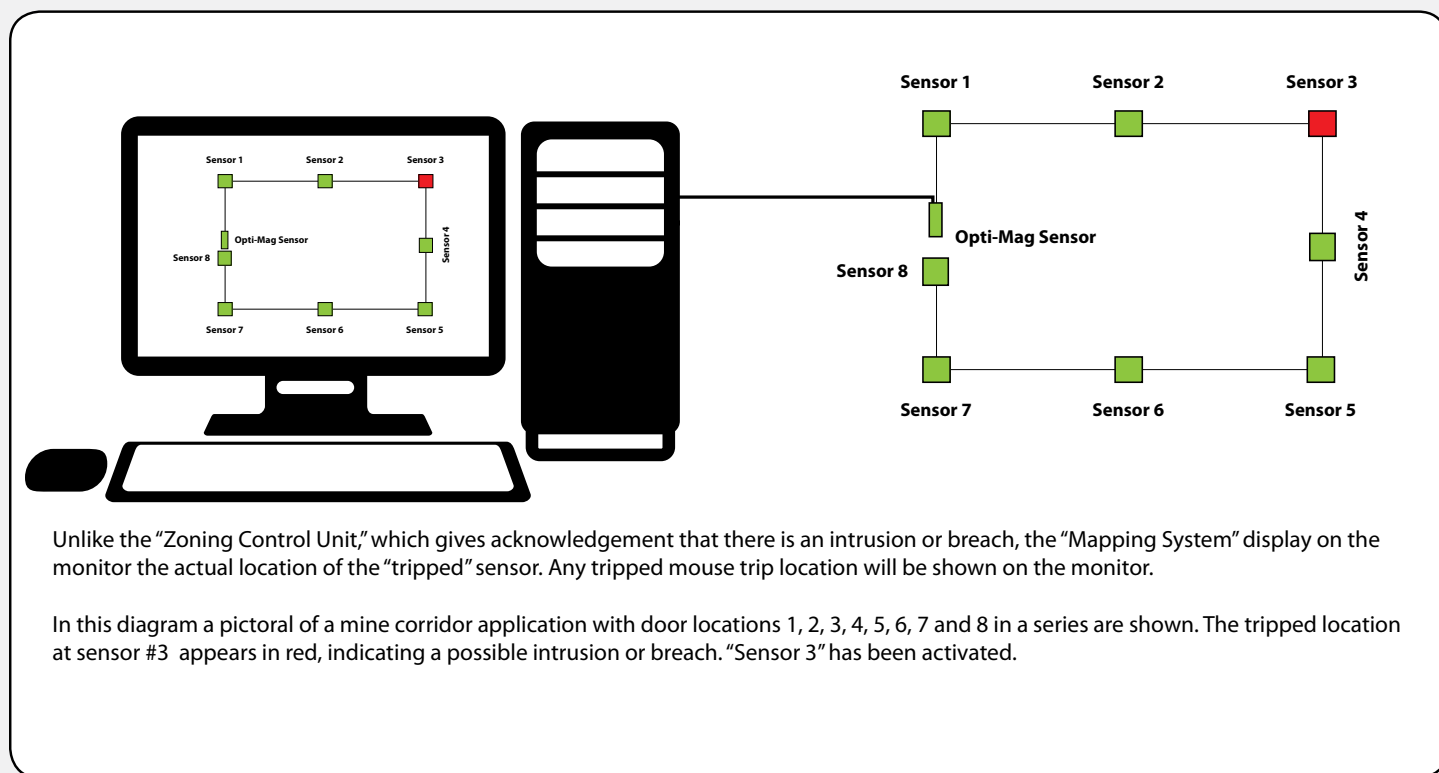

Unlike the "Zoning Control Unit," which gives acknowledgement that there is an intrusion or breach, the "Mapping System" display on the monitor the actual location of the "tripped" sensor. Any tripped mouse trip location will be shown on the monitor.

In this diagram a pictoral of a mine corridor application with door locations 1, 2, 3, 4, 5, 6, 7 and 8 in a series are shown. The tripped location at sensor #3 appears in red, indicating a possible intrusion or breach. "Sensor 3" has been activated.

3. INSTALLATION & CONFIGURATION TECHNIQUES

(FOR MORE DETAILED INSTRUCTIONS REFER TO PAGE 19)

3.1 Perimeter Installation Options

MOUSE TRIP SENSOR

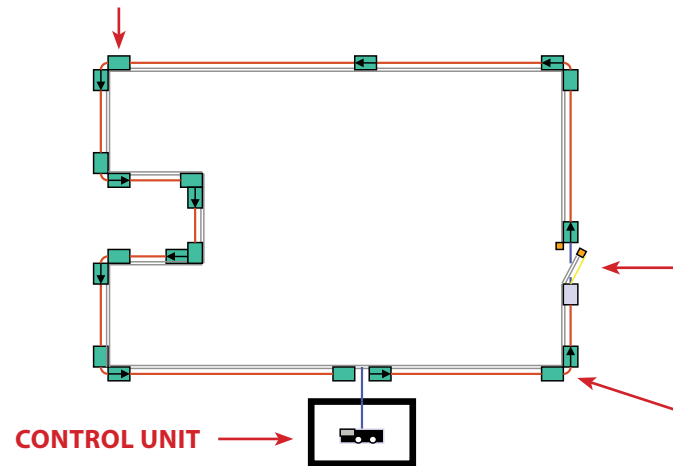

Option 1: Using The Control Unit

Used for smaller perimeters (less than 2500m total length). This installation is good where there is a need for maximum intrusion protection and when the identification of the intrusion location is not necessary.

OPTI-MAG SENSOR FOR GATE SENSING

Note: We recommend using a short length of flexible tubing or the use of a corner bracket on all corners to ensure that the fiber maintains an acceptable bend radius. Contact FIS for bracket part number.

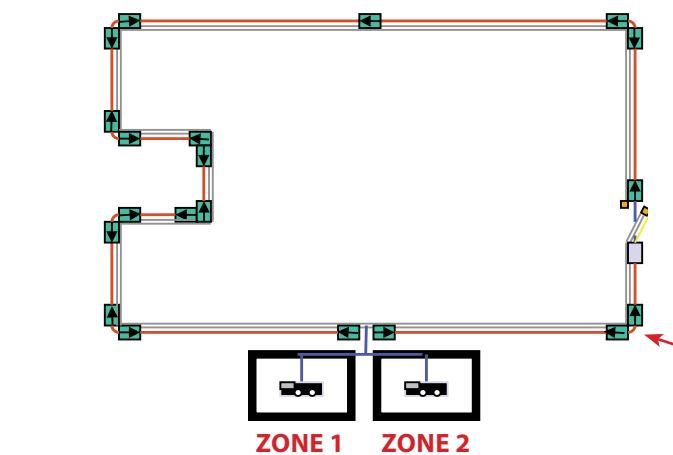

Option 2: Ganging Controller Units

This type of installation is best used where perimeters are larger and zone identification is required. Any number of zones may be installed.

Note: We recommend using a short length of flexible tubing or the use of a corner bracket on all corners to ensure that the fiber maintains an acceptable bend radius. Contact FIS for bracket part number.

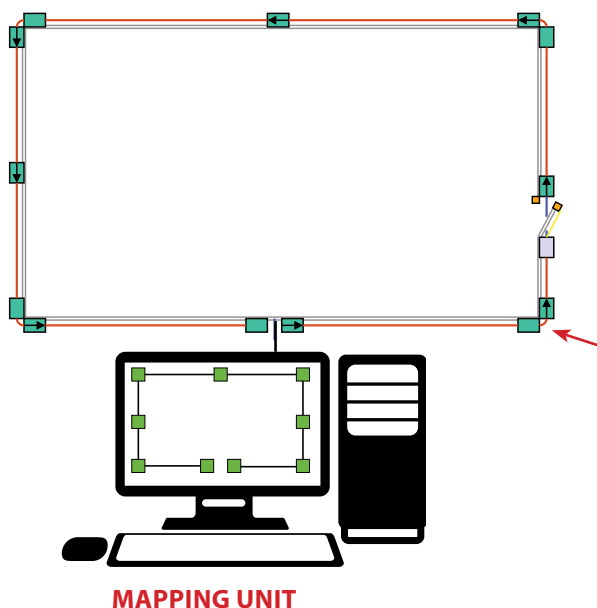

Option 3: Utilizing the Mapping Unit

The mapping unit is used when a manned control center is needed for high levels of monitored security and when intrusion detection and zone location are necessary.

Note: We recommend using a short length of flexible tubing or the use of a corner bracket on all corners to ensure that the fiber maintains an acceptable bend radius. Contact FIS for bracket part number.

3.2 Mouse Trip Configuration Options

Configuration 1: Single Cable Setup

Detects:

- Fence Destruction
- Vehicular Intrusions
- Fence Theft

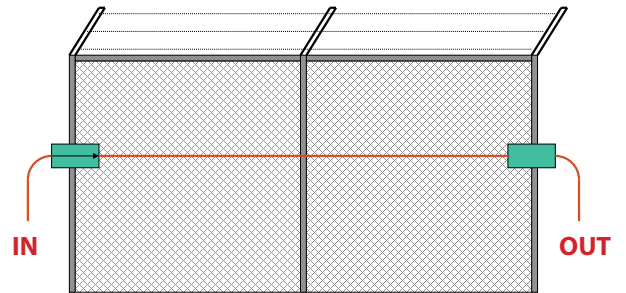

NOTE: IN/OUT MUST LOOP BACK TO THE ZONING CONTROL UNIT OR MAPPING SYSTEM UNIT.

Configuration 2a: Double Cable Setup (increases sensitivity at bottom)

Detects:

- Fence Destruction
- Vehicular Intrusions
- Fence Theft
- Bottom Entry

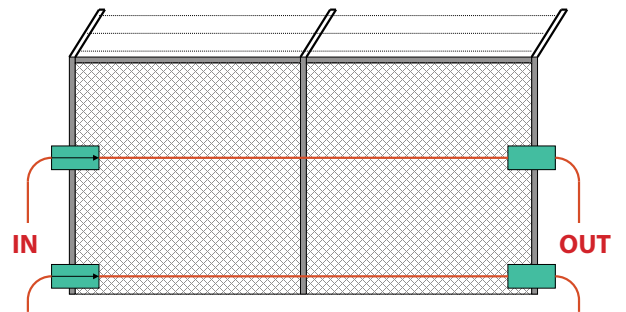

Configuration 2b: Triple Cable Setup (increases sensitivity at top)

Detects:

- Fence Destruction
- Vehicular Intrusions
- Fence Theft
- Bottom Entry
- Climbing
- Ladder Intrusion

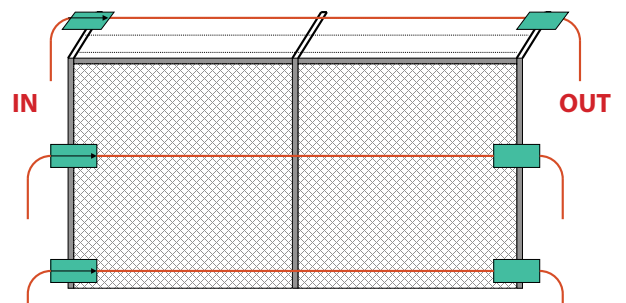

Configuration 3: Multi Cable Setup (highest Level of Protection)

Detects:

- Fence Destruction
- Vehicular Intrusions
- Fence Theft
- Bottom Entry
- Climbing
- Ladder Intrusion
- Large Hole Cutting

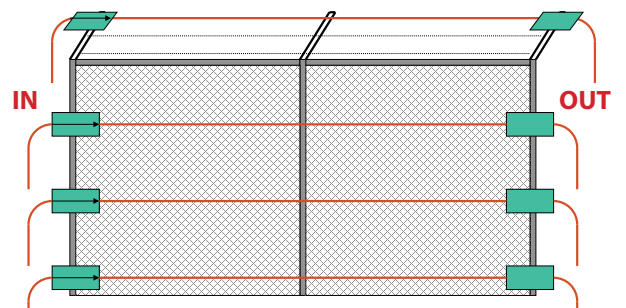

3.1 Using Splice Enclosures (PN: OMS-ENCL)

As mentioned, the Splice Enclosure provides additional protection for interior/exterior fusion (or mechanical) splice locations, or at system perimeter gate locations. It is recommended that Splice Protection Kit (PN: OMS-SPK) be used in conjunction with this enclosure.

Splice Enclosure Mounting Procedure

1. Position the Splice Enclosure on the fence so that the sensing fiber entry grommet is level with the rest of the fiber run.
2. Feed the fibers into the enclosure through the two grommets. Perform splice and mount into splice chip if Protection Kit is not used.

NOTE: This is just one example of an installation technique for the Splice Enclosure. Contact FIS to find out what the best installation technique is for your particular application.



3.2 Using the Splice Protection Kit (PN: OMS-SPK)

As mentioned, the Splice Protection Kit is recommended for use to protect fusion or mechanical splices within the splice enclosure. (Refer to page 10 for more details)

Splice Protection Kit Procedure

1. Before the splice is performed: Insert and center the 4" metal protective tube into the 5" black shrink tube.
2. Slip the 5" black shrink tube containing the metal tube over one cable end, exposing the cable.
3. Insert a 1" clear shrink tube over the exposed cable and the cable to be spliced.
4. Perform fusion or mechanical splice. Carefully follow the stripping and cleaving instructions provided by the manufacturer of the splice you are installing. Remove as little of the outer jacket as possible.

(continued on page 15)



(continued from page 14)

5. Once the splice is complete, position the clear shrink tubes near the end of the outer jacket so that they are approximately 3 1/2" apart as shown in the diagram.
6. Center the metal protective tube and black shrink tube over the splice and the two clear shrink tubes. Carefully heat the clear shrink tube with a controlled flame or heat gun.
7. Making sure everything is centered, secure the protective housing by carefully heat shrinking the black shrink tube.

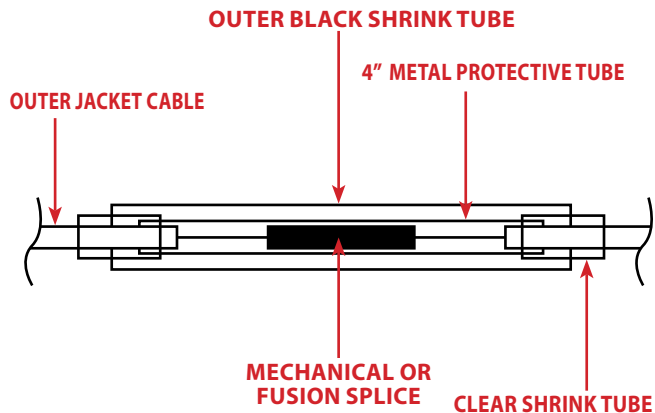

3.3 Mouse Trip Installation - Angled Barbed Wire at Fence Top (PN: OMS-AFTB)

Mouse Trip Sensors are commonly positioned on the angled, barbed wire section at the top of a fence. The following instructions will assist the installer when mounting Sensors in these or similar locations.

1. Attach the Mouse Trip to the existing barbed wire mounting arm.
2. Strap the Mouse Trip and plate assembly to the underside of the barbed wire arm using the provided banding straps.
3. Position Mouse Trip so that sensing fiber is in line with the top most barbed wire.



3.4 Opti-Mag Sensor for Gate Applications (PN: OMS-PRX)

Opti-Mag Sensors can be installed at gate locations to sense perimeter entry and exiting. Each sensor requires two fusion or mechanical splices and splice enclosure for protection. (See diagram below)

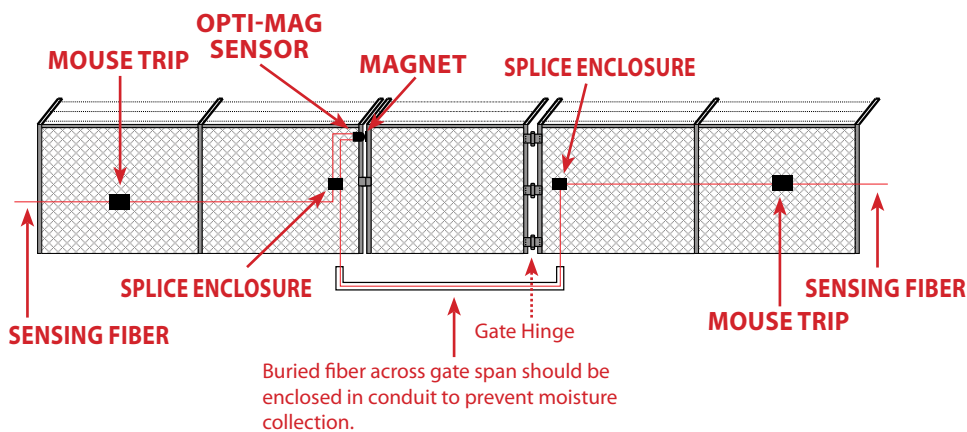

GATE OPENING TRIGGER ALARM *

*A plate mounted above the sensor, which manually swings down, allows gate entry without setting off alarm.

3.5 Using Zip Ties (PN: OMS-DHZT)

Utilizing the double headed UV resistant zip ties, secure the sensing fiber to the fence by following this procedure:

1. Pass the thin end of the tie through the fence and loop the end up and over a joint in the links of the fence. Insert the end into the bottom hole of the zip tie head and pull tight.
2. Leave the tie like this for now; do not loop the end up into the second hole in the zip tie head until you are ready to install sensing fiber.
3. To install sensing fiber create a second loop, but do not over tighten since it will attenuate the sensing fiber. Clip any excess if desired.



STEP 1 SHOWN BEFORE SENSING FIBER IS INSTALLED

3.6 Storage of Fiber After Splicing

Splicing the fiber cable may be required when it is necessary to increase the length of the sensing fiber, or to repair a break along the fence line. Should a break occur, a length of sensing fiber may be spliced into the existing fiber between the two nearest Mouse Trip Sensor locations.

Each Mouse Trip Sensor enclosure contains an internal "fiber well" feature that provides protection to the spliced fiber location. Simply remove the Mouse Trip cover, perform the splice, and then place the spliced connection into the fiber well. Reassemble the cover and then recalibrate the Mouse Trip and Fiber Fence System.



MOUSE TRIP SPLICE PROTECTION LOCATION

- In the illustration provided on page 17 a section of fence has been breached and the fiber has been broken.
- There are Mouse Trips on every third pole (M1 through M4), with the breach occurring between M2 and M4.
- To restore system operation, follow these steps:
 1. Repair the damaged section of fence.
 2. Remove the broken section of fiber by cutting at M2 and M4.
 3. Install a new Mouse Trip on the pole at M3.
 4. Attach a new length of fiber to the fence between M2 and M4, and load the fiber into M3.
 5. Fusion splice the new section of fiber to the existing run at M2 and M4, and place the splices with slack fiber into the Fiber Well in those Mouse Trips.

(continued on page 17)

(continued from page 16)

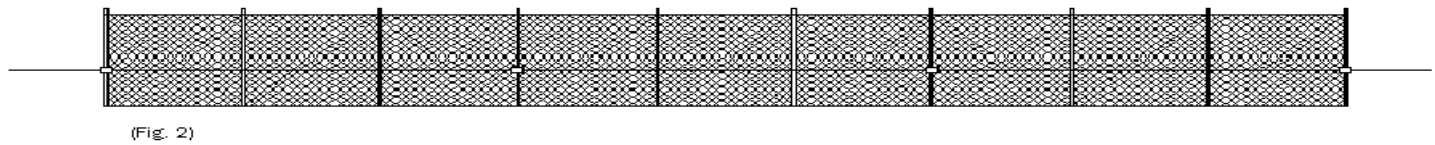
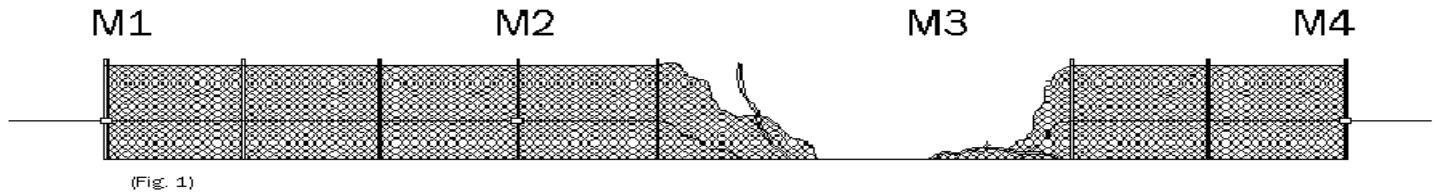

- After splicing, verify quality of splice with OTDR. Re-splice if loss is greater than 0.4dB.
- Replace covers on Mouse Trips, and begin monitoring perimeter. Additional loss may require recalibration.
- If a Fusion Splicer is not available, FIS recommends the 3M Fiberlok mechanical splice. **(PN: 2529.)**
- Installed splice loss should be less than 0.25dB.



3.7 OTDR Testing Installed Fiber Fence System

An OTDR (Optical Time Domain Reflectometer) should be used upon completing installation of the Fiber Fence System.

Upon completing installation:

- Connectorize the IN/OUT cable that runs from the Zoning Control Unit (or Mapping System) to the fence. The Zoning Control Unit or Mapping System may receive FC or SC style connectors.
- Scan the installed fiber with an OTDR. Using the OTDR trace, identify the locations of any of the following events:
 - o Breaks in the fiber
 - o Tripped Mouse Trips
 - o Pinched fiber
 - o High Loss (>0.15dB) fusion splices or (>0.25) mechanical splices

For optimum system performance, locate and eliminate all point losses greater than 0.15dB. Total system loss should be <0.75dB/km.

4. CONNECTING TO THE ZONING CONTROL UNIT

STEP 1. Before turning the unit on, connect both ends of the fiber sensing loop into the fiber loop receptacles on the back panel of the unit.

- This device contains a class I laser. Do not look directly into the fiber loop receptacles while the device is powered.
- The fiber receptacles on the back of the unit are for FC or SC connectors. Be sure the key on the FC connector is lined up with the slot in the receptacle before tightening the connector.

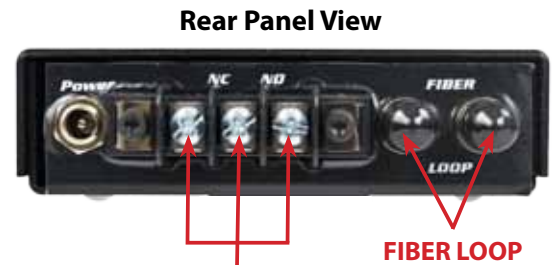

Terminal Block – A 3-pin terminal block is located in the back panel to provide a normally open (NO) and normally closed (NC) contact to trigger an external alarming device (siren, flashing light, etc.). This connection is a switch capable of carrying 3 amps (3A) of current.

STEP 2. Connect the 9V power supply that is included with the unit to the power connector on the back of the unit.



STEP 3. Apply power to the unit by toggling the power switch to the "I" position.

- The green "calibrated" LED will light to indicate that self-calibration of the unit is in progress.
- The green "calibrated" LED will blink once to indicate the self-calibration completed successfully.



STEP 4. It is recommended the alarm be tested by deliberately triggering the unit into alarm condition with a fiber event (fiber attenuation, fiber disconnect, or cover cop activation).

- The red "alarm" LED should light in alarm.
- The audible alarm should sound, if the "Mute" button is off.
- If the unit is in "Latch" mode, the red "alarm" LED and audible alarm will be present even after the alarm event has been corrected. Press the reset button to clear the alarm if in "Latch" mode.

Front Panel View



Front Panel Features:

- Mute** – enables and disables the audible alarm.
- Latch** – allows the unit to remain in alarm, even after the alarm event has been corrected, until the reset button has been pressed.
- Reset** – Press to clear alarm in latch mode after the alarm event has been corrected.

1. DETAILED FIBER FENCE INSTALLATION INSTRUCTIONS

IMPORTANT NOTICE

Fiber Fence Systems **MUST** be installed by fiber optic technicians. Consult a local fiber optic contractor or confirm installation team possesses the ability to: **splice fiber, connectorize fiber, hang fiber, test fiber** and **OTDR operation**.

Required Tool Guide Lines

- Fusion Splicer
- OTDR (Singlemode)
- Battery Powered Drill
- Wrench Set
- TORX™ Screwdriver
- 11/64 Metal Drill Bit
- Measuring Tape
- Black Sharpie
- Electrical Tape

Step 1: Determine Installation Starting Point

The first step is to determine exactly where the Zoning Control Unit or Mapping System will be located. Install ideally in an environment controlled inside room adjacent to the fence. The sensing cable provided with this kit is intended to be run from the control unit directly to the fence. You may find it necessary to bury the sensing cable in a water free conduit. You may choose to use direct bury or aerial cable utilizing a splice enclosure.

If your particular site does not allow for this method of installation, please contact your Fiber Instrument Sales representative for alternative solution recommendations.

Step 2: Mouse Trip Mounting

Identify the first pole on the fence line on which you will mount the first Mouse Trip sensor. Next, determine the distance above the ground that the Mouse Trips will be mounted on the fence location. (Recommended height when utilizing a single layer is four feet.)



Measure up approximately 4ft for the first mark

Figure 1

Using a measuring tape and a permanent marker, measure up from the ground to this desired height and make a mark on the center of the pole. This will mark the bottom mounting screw location for the Mouse Trip.

From the bottom mounting screw location just identified, place a second mark 7 1/8" above the bottom screw locations. Use an 11/64" diameter drill bit to drill a hole at each location marked. (See figure 2 and figure 3.)



Measure 7 1/8" above the first mark and make second mark

Figure 2



Figure 3

Mount the Mouse Trip with two of the #12-14x2 self-tapping screws provided, one through each of the mounting bosses on the Mouse Trip. Note: Do not over-tighten the mounting screws: over-tightening the screws could damage the Mouse Trip. (See figure 4)



Figure 4

Leave the cover on the Mouse Trip for now; repeat the above process on every sixth pole (approx 50' apart) along the fence line until all Mouse Trips are mounted.

Step 3: Zip Tie Installation

The first zip tie should be installed 6" to 8" to the right of the first Mouse Trip, and should be even with the opening in the side of the Mouse Trip. This opening is where the fiber exits the Mouse Trip and continues down the fence line.(See figure 5)



Figure 5

Pass the thin end of the tie through the fence. (See figure 6)



Figure 6

Loop the end up and over the joint in the links of the fence. (See figure 7)



Figure 7

Insert the end into the bottom hole of the zip tie head and pull tight. (See figure 8)



Figure 8

Leave the tie like this for now; do not loop the end up into the second hole in the zip tie head. (See figures 8 & 9)



Figure 9

Move two to three feet to the right of the zip tie, and install the next one. (See figure 9)

Make sure all zip ties are in a straight line, leading from the right side of one Mouse Trip to the left side of the next Mouse Trip.

Continue to install zip ties until there are approximately eighteen zip ties between Mouse Trips or every three feet completing protected fence region.

Step 4: Sensing-Fiber Installation

This step of the installation requires time and patience. Once again, be gentle with the fiber at all times, and move slowly and carefully throughout the process.

Starting at the Fiber Fence Control Unit or splice enclosure, unspool enough fiber (approximately 10ft) to create a loop that may be zip tied next to the first Mouse Trip.

NOTE: These installation instructions are based on installing the sensing fiber in a clock-wise (right-to-left direction, as viewed when facing the front of the Mouse Trip sensor) around the fence perimeter.

The sensing fiber can be installed in a counter-clockwise direction as well. Contact FIS with any specific questions.

Fiber Installation From Right to Left

Remove the cover from the first Mouse Trip. Inside will be two foam seals (one on the left and one on the right, where the fiber enters and exits the Mouse Trip), the main cover gasket, and a small plastic bag filled with the remaining cover screws, as well as the tiny TORX screw that fits into the plunger. Save these parts for now; when the Mouse Trip is loaded, you'll need them to seal the Mouse Trip and secure the cover in place.

Note at the bottom of the Mouse Trip there is a grenade type pin that should remain in position and be removed at the end of installing fiber sensing cable.

Loosen the screw in the Trigger Clamp, but do not remove it completely. The clamp has a rubber pad mounted to it that may stick to the pad in the bottom of the trigger; if this happens, lightly pull on the top edge of the clamp to free it. (See figure 10 and figure 11.)

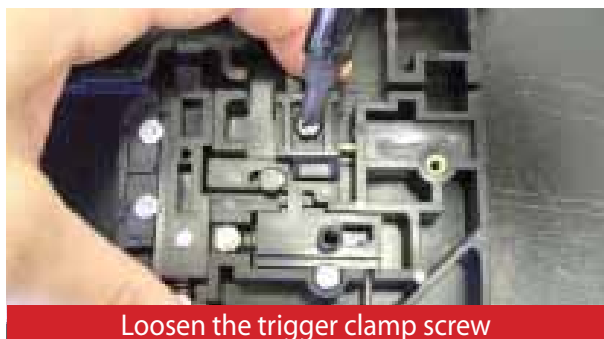

Figure 10

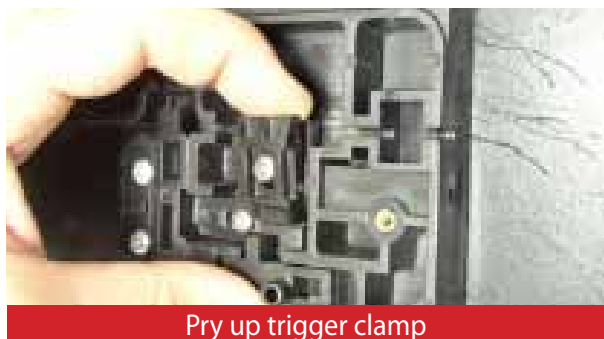

Figure 11

Lay the fiber into the groove in the right side of the Mouse Trip, right next to the trigger. Place the fiber under the trigger clamp, and route it over the top of the plunger. Make sure that the fiber is positioned between the rubber pads in the clamp, not between the hard plastic of the clamp and the trigger. Slowly tighten the screw in the trigger clamp until you can tug on the fiber without pulling it through the clamp (do not over-tighten the clamp; the rubber pads provide enough friction to hold the fiber in place without needing to be tightly clamped). (See figure 12)



Figure 12

Loosen the screw in the fiber clamp on the left side of the Mouse Trip, and lightly pull up on the top edge if it sticks in place. Once loosened, the top edge of the clamp should "stand up" above the pad, thanks to a small spring beneath it. Slide the clamp towards the bottom of the Mouse Trip, uncovering the groove for the fiber to lie in. (See figure 13)



Figure 13

Make a 3" diameter loop with the fiber in the fiber well, and then route the fiber under the fiber clamp and out the groove in the left side of the Mouse Trip. Use a small piece of electrical tape to secure the loop in the fiber well, ensuring the cover won't pinch the loop when it is re-installed. (See figure 14)



Figure 14

Carefully slide the clamp up until it is covering the fiber (be careful not to pinch the fiber). Re-tighten the screw in the clamp. (See figure 15)



Figure 15

Replace the fiber foam seals on either side of the Mouse Trip; insert them narrow end first with the slot facing up. (See figure 16)



Figure 16

Thread the small TORX™ screw into the plunger until the top of the screw is flush with the surface of the plunger. (See figure 17)



Figure 17

Attach the cover and gasket to the Mouse Trip. Make sure that the cover gasket is oriented with the large, square cutout over the trigger area (on the right side of the Mouse Trip), and that the holes in the gasket are aligned with the screw holes in the cover and the Mouse Trip itself. Screw in all 6 of the provided cover screws (including the four that were in the bag and the two that were in the cover originally), but do not pull out the Grenade Pin just yet. **Pulling the pin will be the last step when the rest of the installation is complete.**

Carefully unspool the fiber all the way down to the next Mouse Trip, and then set the spool on the ground.

Starting at the first Mouse Trip, loop the end of each of the zip ties over the fiber and into the second hole in the head of the tie. Do not tighten the zip tie all the way down to the fiber, though; leave a ¼" loop in the tie around the fiber. (See figure 18)



Figure 18

When all of the zip ties between the first two Mouse Trips have been closed over the fiber, remove the cover from the second Mouse Trip and load the fiber as before.

Once the fiber is loaded in the second Mouse Trip, you will need to pull the fiber between the first two Mouse Trips tight. To do this, loosen the trigger clamp until the fiber can be pulled through it; slowly pull the fiber in the direction of the fiber well until it is on the fence. Re-tighten the trigger clamp. (See figure 19)



Figure 19

Continue this process all the way down the fence until the last Mouse Trip is loaded.

Once all the Mouse Trips have been loaded, there should be between 50' and 100' of extra fiber. Do not cut this extra length off; continue to install it on the fence using zip ties as you did all the way to this point.

Before completing the installation by connecting the Zoning Module or Mapping System, check each Mouse Trip one last time to verify that none of them are "tripped". If any are, you will need to reset them before powering up the Zoning Module. To determine if a Mouse Trip has been "tripped," look through the window in the cover of each one. A small orange dot will be visible in the window of a "tripped" Mouse Trip. (See figures 20 and 21.)

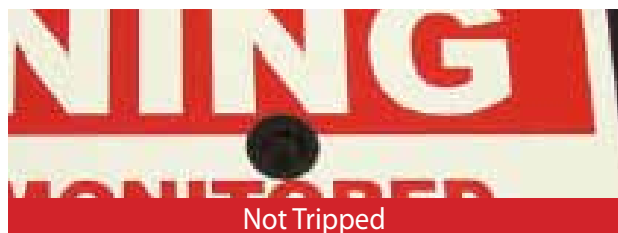

Figure 20

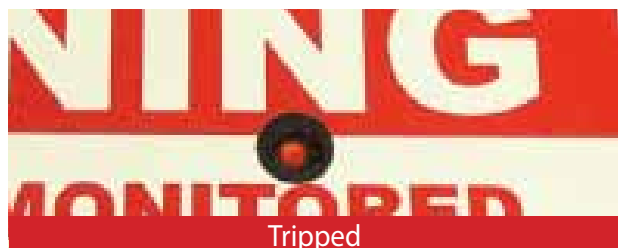

Figure 21

If you have a Mouse Trip that needs to be reset, see Step 6 on this page, "Resetting the Mouse Trip".

Step 5: Connect Sensing Fiber to Zoning Control Unit

Now that the sensing fiber, Mouse Trips, and zip ties have been installed on the fence, you are ready to connect the sensing fiber to the Zoning Control Unit. Make the connections in the following order:

Remove the dust caps from the two fiber optic connectors. They may be a FC or SC style Connector.

Insert the connectors into the "Input" and "Output" jacks on the rear of the Zoning Control Unit. **Note:** there is a small, rectangular "key" on the connector, and a matching "keyway" on the receiving adapter; slide the connector into the receiving adapter so that the "key" aligns with the "keyway."

Push the connector in until it stops, and then twist the rotating nut on the connector clockwise until the nut is finger-tight. It doesn't matter which connector is mated with the "Input" and "Output," as long as both are securely attached. (See figure 22 and figure 23.)

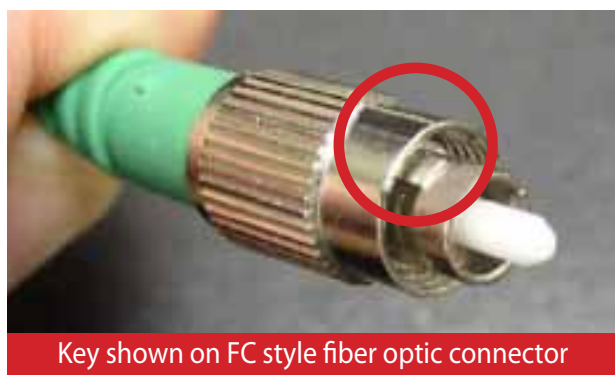

Figure 22



Figure 23

Before plugging in the wall transformer, make sure the switches on the Zoning Control Unit are in the following default positions:

Note: Mapping Units are provided with separate instructions.

Power switch is "Off" (flush at the bottom of the switch).

Mute switch is "Off" (flush at the top of the switch).
"Latch" function is off.

Connect the wall transformer to the Zoning Control Unit by inserting the small power plug into the power input jack on the rear of the Zoning Control Unit. Plug the wall transformer into a standard 110VAC outlet.

Activate the Zoning Module by pressing the top of the "On/Off" switch. The "Calibration" LED indicator should illuminate; if it doesn't, see the "Troubleshooting" section at the end of this manual.

When the power is first turned on the system is operational. Now go back to the fence and remove the Grenade Type Pins from each of the Mouse Trips. In harsh environments it is a good idea to put a small amount of grease or RTV over the fiber entry and exit points in the sides of the Mouse Trips. Applying the grease will ensure that the Mouse Trips remain free of moisture and insects.

The Fiber Fence installation is now complete, and the Zoning Control Unit is ready to be connected to your existing alarm system or autodialer.

Step 6: Resetting the Mouse Trip

It is not required to remove the cover.

Unscrew the small cap on front of Mouse Trip using small screwdriver. Then push the plunger down and then snap the cap back into place.

Step 7: Adjusting the Mouse Trip Sensitivity

If, after a short period of time, you find that one or more Mouse Trips are constantly “tripping” along a certain section of fence, you may want to decrease the sensitivity of those Mouse Trips. To accomplish this, you will need the medium TORX™ screw driver. Insert the tool into the adjustment screw in the right side of the Mouse Trip and turn the tool clockwise to decrease the sensitivity. One full turn is usually enough to start with; if you are still experiencing false alarms a few days later, you can always go back and turn it down a little more.

Note: FIS offers a Tension Gauge (PN: OMS-TNGE) for the Mouse Trip that will allow you to measure the amount of force required to activate a Mouse Trip; this tool is very useful if you would like to set the tension on all of your Mouse Trips the same.

What to Expect

Once installed and operational, the Fiber Fence system is truly a “set and forget” component of your overall security system.

The Zoning Control Unit, Mouse Trips, sensing fiber, and zip ties are maintenance-free (other than for cosmetic cleaning of the Zoning Control Unit) and should not require any attention unless an intrusion is detected.

In the event of an intrusion, there are three ways that the alarm in the Fiber Fence can be triggered;

1. Should the intruder bend the fiber (without breaking it or setting off a nearby Mouse Trip Sensor)
2. If the fiber is broken
3. If a Mouse Trip or Opti-Mag sensor is activated

In any of these instances, an alarm will sound and the relay contacts in the back of the Zoning Control Unit will change state.

After an intrusion, it is recommended to begin monitoring the fence again as soon as possible:

- First, try pressing the reset button on the front if using Zoning Module. If, during the intrusion, the fiber was only bent enough to activate the alarm, pressing this button would reset the system (if the Latch mode is off, this will already have happened automatically). If the alarm doesn't reset, you will need to inspect the Mouse Trips and the fiber.
- Inspect the entire fence line to determine the condition of the fiber; look for any unusual bends or a break. In the event a break in the fiber is discovered, you will need to contact a trained fiber optic technician to splice together the break in the fiber.
- Inspect each of the Mouse Trips specifically to determine

if the orange dot on the plunger is visible in the window (indicating a “tripped” Mouse Trip). If the dot is visible, you will need to reset the Mouse Trip (refer to Step 6 on page 23: “Resetting The Mouse Trip”).

- If the calibration light does not light up the fiber is broken; has too much loss due to bends; or is not connected.

The most effective means of troubleshooting a Fiber Fence System is by using an OTDR to check the fiber condition and/or dB loss. The optional Mapping Unit uses its own, self contained OTDR that may be utilized for testing and troubleshooting.

Factory Support provided by calling:

1-800-5000-FIS(347)

OPTI-MAG SENSOR OMS-PRX



Opti-Mag Sensors use fiber optic based technology that allows sensing in locations that can extend for miles. They require no electrical power at the sensor location, making them extremely useful in remote areas where there is often no electrical service. They can also be used in flammable environments where electrical arcing (sparking) is prohibited. Being that there are no external moving parts, Opti-Mag Sensors have a long, reliable sensing life. The Opti-Mag Sensor does not require being in direct contact with the surface it is sensing.

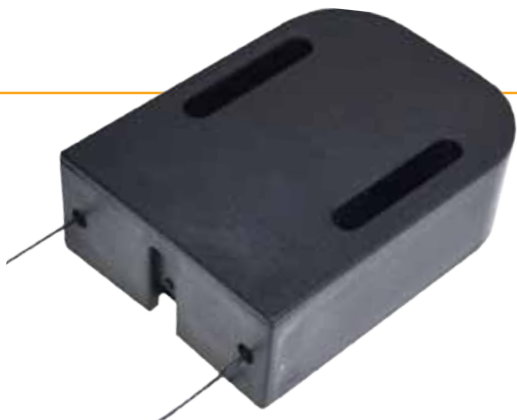

KEY FEATURES

- Impact resistant plastic housing, stainless steel spring and nickel/copper/nickel triple coated NdFeB permanent magnet for maximum longevity
- Spark-Free sensing device
- Fiber optic based and requires no electrical power
- Long range sensing capability
- Has no external moving parts, eliminating failure due to corrosion or mud buildup
- Sensor trips in <0.5 seconds, provides an instant alarm and location within seconds
- Elongated mounting slots for flexible mounting options
- Weatherproof housing, suitable for use in damp or water-splash environments

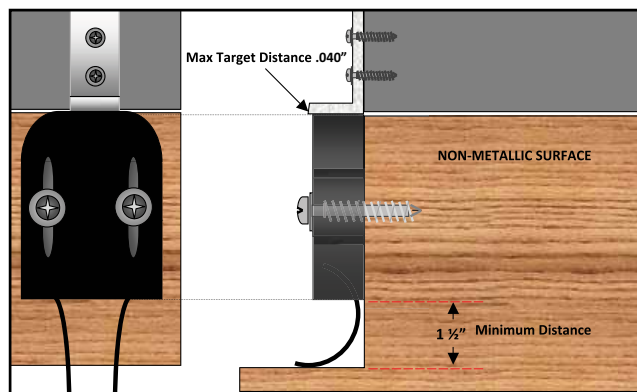
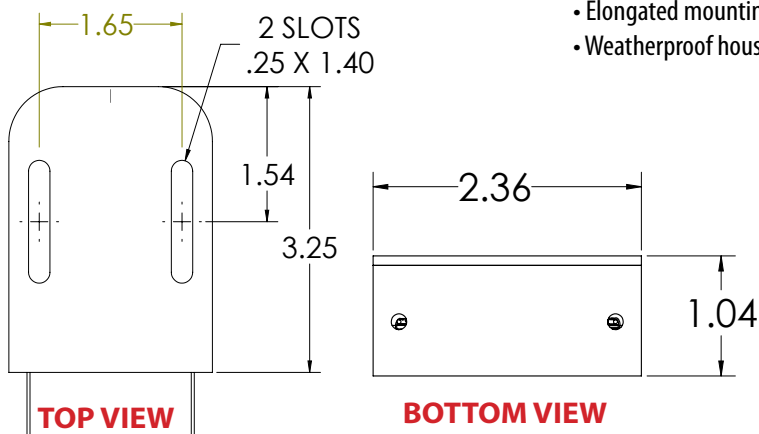

Magnet/bracket assembly **PN: OMS-MBRKASSY** may be used on sensing metal to increase sensing distance.

SPECIFICATIONS

Fiber Type	9/125, 900µm UV Resistant Jacket
Operating Temperature	-30°C to +63°C (-22°F to +145°F)
Minium Ferrous Metal Target	2" x 2" x 1/8" thick
Dimensions	3.250"H x 2.375"W x 1.125"D
Weight	6.0 ounces
Maximum Target Distance	0.04 inches
Durability (with out magnet)	5000 cycles
Housing Material (designed for intermintent sensing)	Glass Filled ABS
Attenuation	1dB



**ZONING CONTROL UNIT 850NM (STANDARD)
OMS-CMV**
**ZONING CONTROL UNIT 1310NM (EXTENDED)
OMS-CML**



The Zoning Control Unit is the heart of both the Opti-Mag Sensor and the Fiber Fence Sensor Systems. Using a laser, the Control Unit sends light through the fiber optic cable to one or more Opti-Mag or Mouse Trip sensors to which it is connected. When one of those sensors detect an event, the amount of light sent back to the Control Unit is reduced, thus causing the Unit to trigger a relay switch that can provide any number of desired outcomes. Multiple control units provide multiple zone location sensing. For example, the relay can be configured to sound an alarm to an automated telephone dialup system.

The Zoning Control Unit is available in two different light source models; an 850NM VCSEL unit for standard (3km) transmission range applications, or a 1310NM high-power laser for use in extended range applications (10km.) Use the appropriate Zoning Control Unit based on the total perimeter length of the installation application.

KEY FEATURES 850NM

- 3km Transmission Range
- Automatic Calibration
- Easy to install & use
- 8dB Dynamic Range
- Less .5 sec response time

KEY FEATURES 1310NM

- 10km Transmission Range
- Automatic Calibration
- Easy to install & use
- 23dB Dynamic Range
- Less .5 sec response time

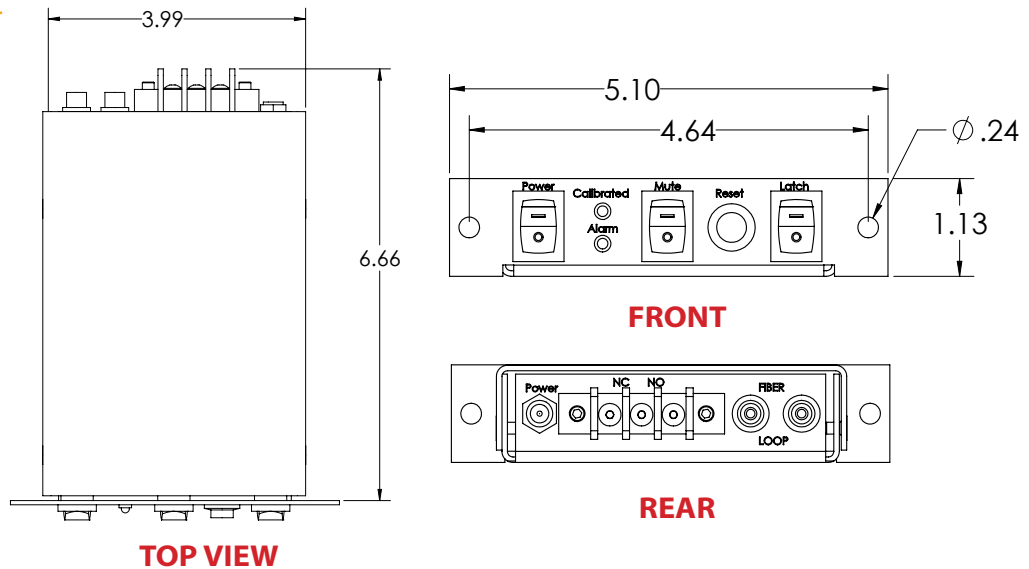

850NM (STANDARD) SPECIFICATIONS

Operating Wavelength	850nm SM Fiber
Optical Connectors	FC or ST
Dynamic Range	8dB*
Operating Temperature	0° to 50°C
Power Requirements	110 VAC 50-60Hz
Operating Voltage	9Vdc 300mA (center positive)
Fiber Type	Sensing Fiber 9/125µm

*All specifications tested with 9/125µm sensing fiber

1310NM (EXTENDED - LASER) SPECIFICATIONS

Operating Wavelength	1310nm SM Fiber
Optical Connectors	FC or ST
Dynamic Range	23dB*
Operating Temperature	0° to 50°C
Power Requirements	110 VAC 50-60Hz
Operating Voltage	9Vdc 300mA (center positive)
Fiber Type	Sensing Fiber 9/125µm

* 220 Vac - 9Vdc 1A is available for both units upon request

MOUSE TRIP SENSOR OMS-MT



Mouse Trip Sensors are designed to be mounted to the fence line and operate with 9/125µm sensing fiber. When tripped, an internal plunger creates a loss of light which is recognized by the Zoning Control Unit and activates an alarm. Mouse Trip Sensors are water resistant, dust proof, UV protected, and are designed to withstand extreme temperature fluctuations for dependable performance during extended deployment in harsh weather environments.

All Mouse Trip Sensors come equipped with a reset feature that allows for quick resetting using a special tool (included) without having to open the Unit.

The Mouse Trip Sensor requires minimal maintenance throughout its service life, and once installed will provide many years of reliable protection.

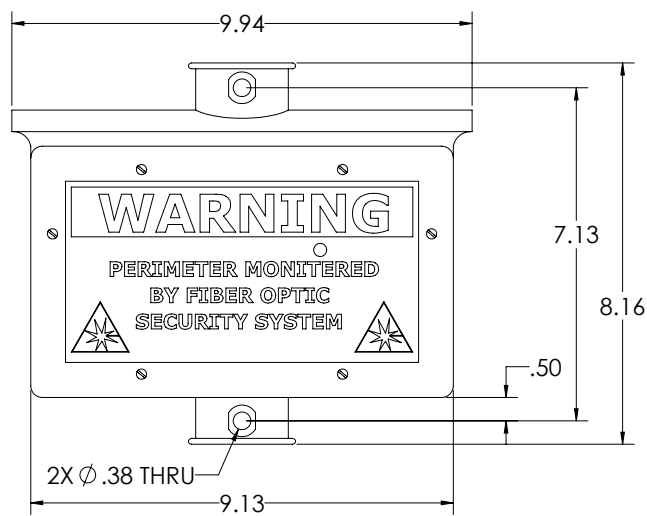

FRONT VIEW

KEY FEATURES

- UV Protected
- No Power Supply Required
- Compact and Lightweight
- Multiple Mounting Configurations
- Quick Resettable Version Also Available
- 8dB Dynamic Range

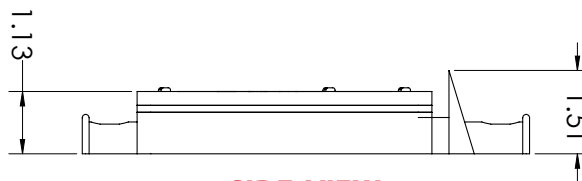

SIDE VIEW

SPECIFICATIONS

Materials	UV Protected ABS
Operating Temperature	-20°C to 60°C (-68°F to +140°F)
Power Requirements	None
Dimensions	9.75" L X 3.1" W X 6.00" H
Fiber Type	9/125µm
Mounting Type	Pole, Wall (Concrete or Brick)

FIBER FENCE / OPTI-MAG MAPPING SYSTEM OMS-MAP

The optional Mapping System provides the ability to quickly identify the exact location of a tripped sensor, such as that resulting from a security breach. Using its integrated OTDR technology, the Mapping System's software graphically identifies the tripped sensor on a facility photo or map being displayed on the System's monitor.

The Mapping System option replaces the standard Zoning Control Unit.

Fiber Fence Mouse Trips, Opti-Mag Sensors, as well as third-party security devices can be used with the Mapping System to monitor perimeter fencing, doors, windows, access panels, control valves, switches, manhole covers and more. The System can also integrate and display a wide range of security devices on a single facilities monitor. The Mapping System has an 18dB dynamic range. The Mapping System includes the Mapping Software, mouse and display monitor.

Using the Mapping System with Fiber Fence Mouse Trips and Opti-Mag Sensors

The optional Mapping System uses OTDR technology to detect tripped Fiber Fence Mouse Trips or Opti-Mag Sensors. Tripped sensor locations may indicate an intrusion attempt anywhere along the secured perimeter or a movement in the position of a door, cover or valve handle. The Fiber Fence System is capable of monitoring perimeters of up to 10km (6 miles) in length, without requiring electrical power anywhere along the perimeter. The Opti-Mag Sensor does not require electricity and can be used in flammable environments where electrical arcing is prohibited. For more information on the Fiber Fence or Opti-Mag Sensor Systems, contact Fiber Instrument Sales.



KEY FEATURES

- Integrated 1310nm control module
- 8 to 10Km Transmission Range
- Automatic Calibration
- Monitor, Mouse and Keyboard Included
- 18dB Dynamic Range

SPECIFICATIONS

Operating Wavelength	1310nm SM Fiber
Optical Connectors	FC
Dynamic Range	18dB*
Operating Temperature	0° to 50°C
Power Requirements	110/220 VAC 50-60Hz
Fiber Type	9/125µm

161 Clear Road • Oriskany, NY 13424 Tel: 315.736.2206 • Fax: 315.736.2285
 fiberinstrumentsales.com | info@fiberinstrumentsales.com | 1.800.5000.FIS (347)

Application Guide and Quote Form

Name : _____

Company : _____

Email : _____

Phone : _____

Address : _____

City : _____

State : _____ Zip Code : _____ Country : _____

Application : _____

(fence perimeter, manhole cover, sewer, chemical plant, pipeline, oil platform, mining operation, bridge)

Please provide us with the following information regarding your application:

1. What sensing method do you plan to use? Opti-Mag Fiber Fence Both

2. How many sensor locations are required? _____ Opti-mag(s) _____ Mouse Trips

3. How many Control Units are required? _____ Standard Range _____ Extended Range

4. Is it desired to group or zone any sensors? _____ # of zones

5. Is Mapping capability required? _____ Yes _____ No

6. Approx. length of sensing fiber required? _____ feet

(Note: Simplex cable must return back to Control or Mapping Unit)

7. Please provide a sketch of the layout of the required application in the area provided on the next page. Also provide any supportive documentation in the form of technical drawings, maps or photographs of application.

Upon request FIS will recommend an installer.

8. Contact Information for Fiber Optic Contractor performing installation:

Company Name: _____

Contact Name: _____

Phone: _____

Address: _____

Zip Code: _____ State: _____

Email: _____

9. For Opti-Mag applications, please provide a sketch of the proposed application, noting the following:

- **Sensor locations (Opti-Mag)**
- **Distance between sensors**
- **Distance from Control Unit to 1st sensor**
- **If zoning, indicate sensors to be included in each zone**
- **Indicate Mapping or Control Unit location**
- **Show all approximate critical distances**

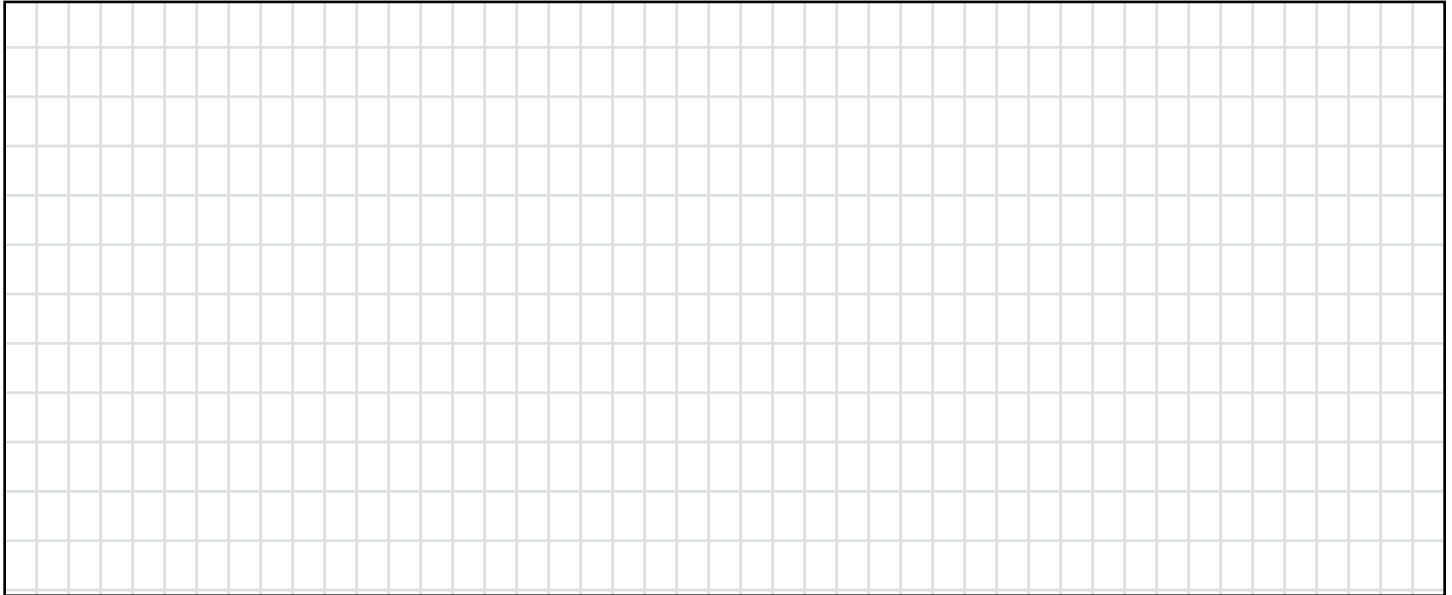

9. For Opti-mag applications, please provide a sketch of the proposed application, noting the following:

- **Sensor locations (Mouse Trips)**
- **Distance between sensors**
- **Distance from Control Unit to 1st sensor**
- **If zoning, indicate sensors to be included in each zone**
- **Indicate Mapping or Control Unit location**
- **Show all approximate critical distances**
- **indicate all gate locations**

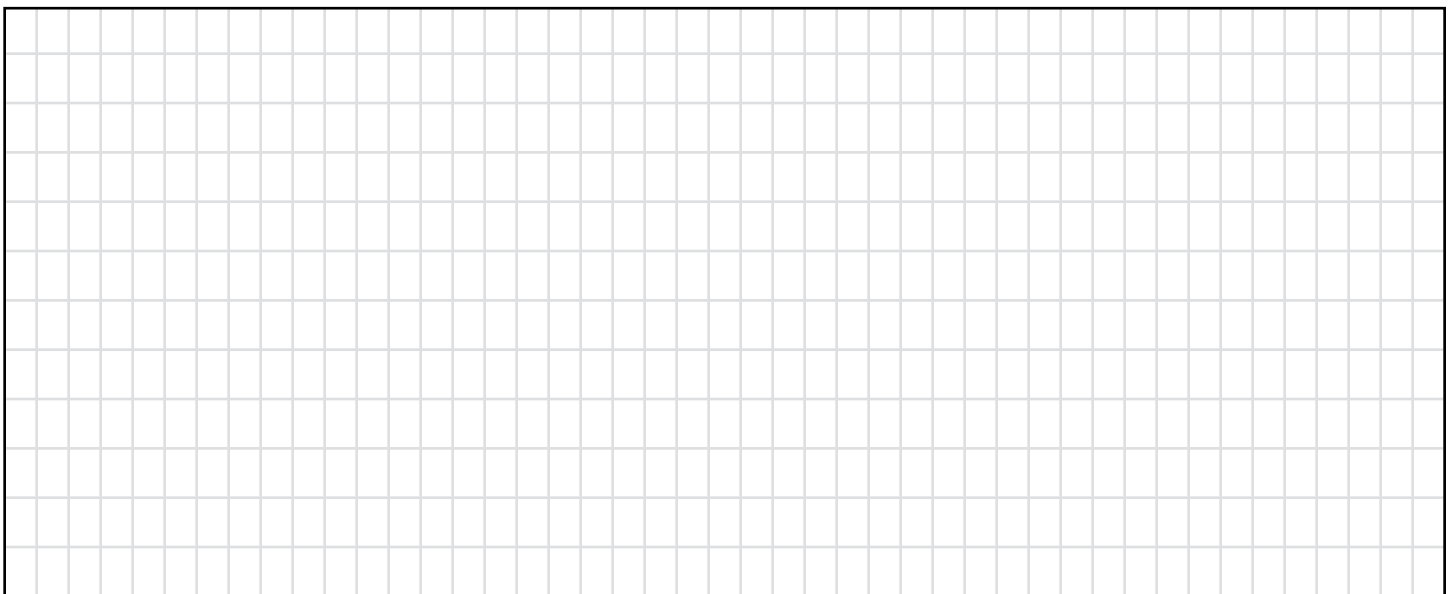

GIOTTO

E N T E R P R I S E S

The synergistic value of our affiliate companies' expertise and unmistakable dedication to quality has earned our organization the reputation of being "the key solution provider" across a wide variety of industries and markets.

From fiber optics to injection molding and precision manufacturing to metal fabrication, with 251,000 sq ft of production space, the depth and breadth of our manufacturing experience continues to be just one reason why world-class companies across the globe continue to put their trust in the excellence of our products and services.

Our combined thirty year history of exceptional service enables us to *offer leading value and top quality, deliver custom solutions, provide the safety of the buy and profits you deserve.*



"FIS" has delivered fiber optic products world-wide since 1985. As a full-line distributor and manufacturer, FIS maintains one of the largest product inventories in the industry.

From engineering specialty fiber optic components, to equipment rentals, to its highly-acclaimed customer training through FIS University, FIS and its highly trained sales staff are nationally and internationally recognized as the fiber industry's "premier problem solvers."

- Nation's leading fiber optic distributor
 - All major lines
 - \$10 million inventory
 - Over 7,000 products in-stock

- Services
 - Equipment rentals
 - Calibration services
 - Domestic & worldwide fiber optic training programs

- Custom Manufacturing
 - Test equipment
 - Custom fiber optic assemblies
 - Custom pre-loaded hardware

☎ 800-5000-FIS
(315) 736-2206

☎ (315) 736-2285

✉ info@fiberinstrumentsales.com

www.fiberinstrumentsales.com



FERMER PRECISION
INCORPORATED

Fermer Precision was founded in 1947 and has evolved from a highly respected tool and die shop into one of the largest ISO/TS 16949:2009 production CNC machining facilities in Upstate New York.

Fermer is an industry leader in machining components used in automotive, emission control, pump and compressor, and firearm components. With some 93 machines and in-house fixture build facilities, the company is capable of both high and low volume machining programs.

- Specializing in CNC machining of all types of castings & forgings
- In-house tool & fixture capabilities
- Wire & plunge EDM

- Manufacturing & supply chain integration
- Casting leak testing & light assembly

Industry certifications:
ISO/TS 16949:2009
ISO 9001:2008
Federal firearms license

☎ (315) 822-6371

☎ (315) 822-6300

✉ sales@fermerprecision.com

www.fermerprecision.com



FIS Blue is the premier manufacturer/supplier of fiber optics with broadcast and military harsh environment applications. FIS Blue's product line includes cable assemblies that can withstand rough handling and harsh outdoor environments, typical of both broadcasting and military applications.

- Broadcast & military/tactical fiber optic cable assemblies, test equipment, panels & enclosures

- Expanded beam fiber optic cable connectors
- Engineering & application support

- Custom manufacturing & In-house inventory

Industry certifications:
ISO 9001:2008
49923/A/0005
GSA-3SF-0484X

☎ 877-347-0091

☎ (315) 768-7038

✉ info@fisblue.com

www.fisblue.com

In addition to the Fiber Fence and Opti-Mag Sensor Systems, we invite you to learn more about the full family of companies that form Giotto Enterprises.



TLC has over 20 years of industry experience in manufacturing high quality fiber optic cable and tubing for a wide range of applications including data center and building premise cable installations.

One of TLC's key areas of expertise is producing interlocking armored cable, which when utilized eliminates the need for traditional cable ductwork thus saving installation time and expense. TLC utilizes Corning fiber in its manufacturing processes, and in addition to its extensive on-hand inventory, will design and manufacture a cable to customer specification.

- Micro-distribution cable - 144 fiber
- Ribbon cable
- Interlocking armored cable
- Tight-buffer indoor & indoor/outdoor
- Dry loose tube indoor/outdoor

- Breakout cable & kits
- Furcation tubing
- Plastic optical fiber
- Extensive inventory for fast delivery
- Engineering & application support services
- Custom manufacturing capabilities

Industry certifications:
ISO 9001:2008
49923/A/0003
Shipping RoHS
Compliant Products

☎ 888-571-1111
(315) 736-7384

☎ (315) 736-1927

✉ sales@thelightconnection.com

www.thelightconnection.com



MSi is a premier ISO 9001:2008 injection molding facility recognized for its ability to provide customers with domestic-based experience, quality and delivery at globally competitive price structures.

MSi is a leading contract molder of precision plastic components used worldwide in a variety of medical, electronic connector, automotive and fiber optic industry markets.

- 24 injection molding machines
- 550 ton, 96 oz. max capacity
- Overmolding & insert molding specialists

- Product development & quick-turn protos
- Short-run to high-production capabilities
- Manufacturing & supply chain integration

- Mold design, build & verification expertise
- Printing, hot-stamping & light assembly
- Wire & plunge EDM

☎ (315) 736-2412

☎ (315) 736-0486

✉ info@moldingsolutionsinc.com
www.moldingsolutionsinc.com

Industry certifications:
ISO 9001:2008 49923/A/0004



FGR International is a manufacturer/distributor of UL, CUL, CSA and TUV approved electromechanical safety relays used extensively in the elevator, rail, signaling, automated machinery, and other environments requiring highly reliable safety control equipment.

- Large inventory of safety relays for: railroad & subway signaling; elevators, escalators & cranes; door & gate drive systems; robots & industrial machines; emergency stop modules; two-hand operating devices; light barriers & curtains; speed controls; din-rail safety modules

- Product customization for specialized applications
- Corporate training programs & consulting services

Industry certification:
ISO 9001:2008
49923/A/0002

☎ (315) 737-2148

☎ (315) 736-0874

✉ info@fgri.com

www.fgri.com



161 Clear Road, Oriskany, NY, 13424

1.800.5000.FIS(347)