

# FIS 12 PORT WALL MOUNT ENCLOSURE

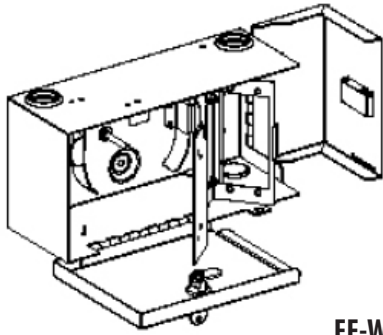

**FF-WM012**



## FEATURES

- Double Door Entry with Lock
- Top and Bottom Entry Hole
- Dust Proof Grommets
- Splicing and Patching Capability
- Holds 2 Adapter Plates ( not included )
- Rugged 16 Gauge Steel, Available Black or Beige
- Holds 2 Splice Tray (not included)

## SPECIFICATIONS

<b>Dimension</b>	12.29"L x 6.46"H x 5.06"W
<b>Capacity</b>	2 Adapter Plates, 2 Splice Tray (F1-SPL12 or 1120-SSTA)
<b>Material</b>	16 Gauge Steel
<b>Coating</b>	Electrostatically Applied Polyester Powder Coat

## ORDERING INFORMATION

<b>FF-WM012</b>	Two Panel Fiber Distribution Unit, Wall Mount, Off-White
<b>FF-WM012-BLK</b>	Two Panel Fiber Distribution Unit, Wall Mount, Black

## RECOMMENDED SPLICE TRAYS

<b>F1-SPL12</b>	Metal Splice Tray, 12 Position Fusion Splice Chip, 6.5"L x 4.7"W x .42"H
<b>1120-SSTA</b>	Metal Splice Tray, 12 Position, Multiple Splice Chips, 6.5"L 4.75"W x .05"H

# FIS 12 PORT WALL MOUNT ENCLOSURE

## TECH DRAWING

