

# FIS 24 POSITION ALUMINUM SPLICE TRAY, 8.5" L

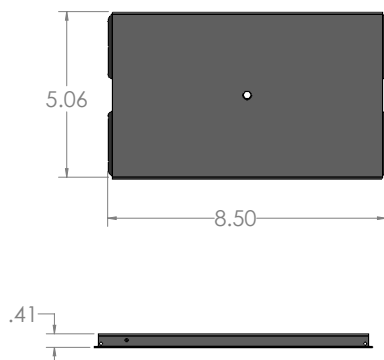

## FEATURES

- 24 Position Fusion Splice Tray
- Fits Most Standard Enclosures
- Lightweight, Rigid Aluminum
- Self Adhesive Splice Chip
- Fiber Tie Downs
- Snap On Lid

The FIS Aluminum Splice Trays are compact, lightweight, and available with multiple splice holding chip and cover options. Choose the right tray for your applications. All trays are preconfigured for standard heat shrink fusion splices unless otherwise stated.

## SPECIFICATIONS

<b>Dimensions (LxWxH)</b>	8.50"L x 5.06"W x .41"H
<b>Material</b>	Black, Powder Coated, .032" Aluminum
<b>Accessories Included</b>	Zip Ties, (2) 12 Position Fusion Splice Chips, Tray Label, (4) Adhesive Velcro Dots

## ORDERING INFORMATION

<b>F1-SPL24-8.5</b>	Metal Splice Tray, 24 Position Fusion Splice, Black
---------------------	---

## SPLICE TRAY FITS INTO

F1-RM1RU3X	1RU Rack Mount 3-LGX Panel	F1-DW2X	Wall Mount 2-LGX Panel
FF-RM2RU4X	2RU Rack Mount 4-LGX Panel	F1-DW4X	Wall Mount 4-LGX Panel
FF-RM2RU6X	2RU Rack Mount 6-LGX Panel	F1-DW8X	Wall Mount 8-LGX Panel
F1-RM4RU12X	4RU Rack Mount 12-LGX Panel	F1-DW12X	Wall Mount 12-LGX Panel
F1-RM8RU24X	8RU Rack Mount 24-LGX Panel		
F1-RMSP4RU4X	4RU Rack Mount Splice & Patch		
F1-RMSP8RU12X	8RU Rack Mount Splice & Patch		