

# Cable Runway & Accessories

## Tubular Stringer Style - 1½" (Boxed)

- Ladder type cable runway for communication cabling pathways
- Mounts to ceilings, walls, floors, relay racks, and electronic enclosures
- ⅜" (9mm) x 1½" (38mm) x 0.049" (1.2mm) tubular steel stringers
- ⅜" (9.5mm) x 1½" (38.1mm) steel tube welded rungs spaced 12" (305mm) on center
- All finishes are UL Classified as suitable as an equipment grounding conductor (File number E60548)
- Individually boxed in a carton suitable for shipping
- Available palletized without individual boxes for larger installation projects
- Material: ASTM A513 grade 1008 steel tube
- Finish \_\_\_\_: Flat black powder coat (FB)  
Telco gray powder coat (TG)  
Yellow zinc (YZ)

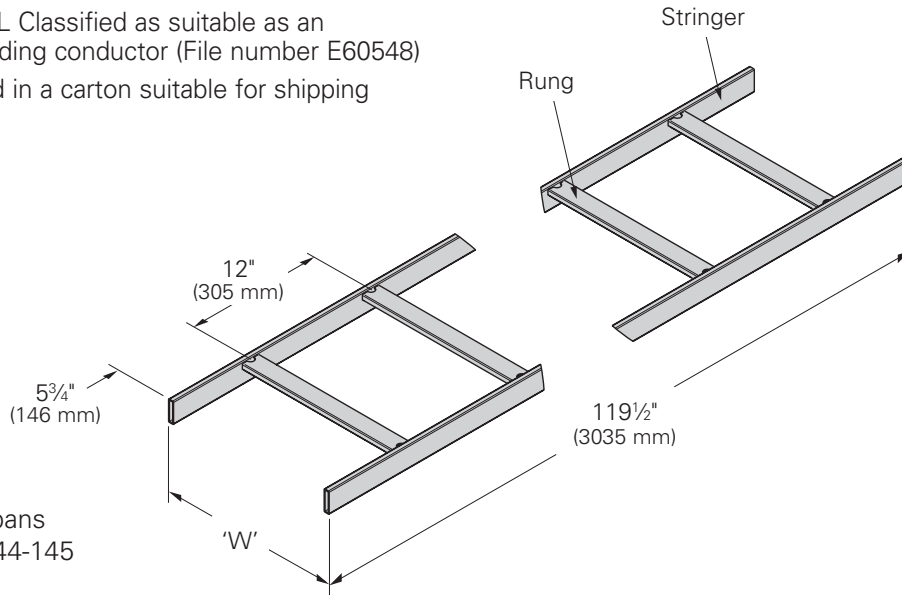

Note: For runway pans see pages 144-145

Series Number	Stringer Dimensions	Span		Recommended Load		Max. Load @ ⅝" Deflection		Deflection Multiplier
		Ft.	(m)	Lbs./Ft.	(N/m)	Lbs./Ft.	(N/m)	
SB17U		4	(1.22)	149	(2174)	347	(5062)	0.0018
		5	(1.52)	95	(1386)	145	(2115)	0.0043
		6	(1.83)	66	(963)	70	(1021)	0.0089

### UL Cross Sectional Area

0.40 in<sup>2</sup> (2.58 cm<sup>2</sup>)

### Design Factors for (1) Rail

Area = .174 in<sup>2</sup> (1.12 cm<sup>2</sup>)

S<sub>x</sub> = .056 in<sup>3</sup> (0.92 cm<sup>3</sup>)

I<sub>x</sub> = .419 in<sup>4</sup> (17.44 cm<sup>4</sup>)

## SB17U Tubular - 1½" (38mm) Stringers

Part Number	'W' Width		Weight	
	In.	(mm)	Lbs.	(kg)
SB17U06B__	6"	(152)	18.0	(8.2)
SB17U09B__	9"	(228)	21.0	(9.5)
SB17U12B__	12"	(305)	23.0	(10.4)
SB17U15B__	15"	(381)	25.0	(11.3)
SB17U18B__	18"	(457)	28.0	(12.7)
SB17U24B__	24"	(609)	32.0	(14.5)
SB17U30B__	30"	(762)	37.0	(16.8)
SB17U36B__	36"	(914)	41.0	(18.6)

### Rung Profile



⅜" x 1½"

.049 thick

Specify part number and finish when ordering.